

**NFPA 99 Compliant Triplex “Oil-Less” Reciprocating Medical Air Package
7.5 HP Vertical Stacked Space Saver with Desiccant Dryers**
Air Compressor Package

- Fully compliant with the latest edition of NFPA 99
- Three oil-less reciprocating air compressors with inlet filter and isolation valve
- Three motors
- ASME coded corrosion resistant air receiver with bypass
- Duplex desiccant air dryer system with purge control and piped with duplex pre-filters, after filters and regulators
- Triplex control panel with HMI control monitoring system
- All discharge air piping and fittings - ASTM B-819 copper tubing, brass and/or stainless steel
- All brazed joints are per NFPA 99
- All discharge flex connectors - braided, 304 stainless steel
- Individual compressor isolation valve
- All components completely pre-piped and pre-wired to single point service connections
- All interconnecting piping and wiring is completed and operationally tested prior to shipment
- Liquid tight conduit, fittings and junction boxes for all control and power wiring

Air Compressor Module

- Continuous duty rated with permanently lubricated, sealed bearings
- Air-cooled single stage reciprocating type
- Corrosion resistant reed type valves with stainless steel reeds
- Compression rings and rider rings - made from a long life, fluororesin material designed for continuous duty operation
- Crankshaft constructed of a durable nodular graphite cast iron not aluminum
- Crankcase fully supported on both ends by heavy duty ball bearings permanently lubricated and sealed
- Cast aluminum alloy cylinders treated for optimum corrosion and wear resistance assure maximum heat dissipation
- Cylinder sleeves not required
- Insulated “heat cut” piston pin minimizes heat transmission from the piston wall to the piston pin needle bearing
- Connecting rod - one-piece design for maximum reliability
- V-belt drive with means of adjustment
- OSHA approved, totally enclosed belt guard
- High discharge air temperature shutdown switch wired to the compressor control system for each compressor
- Discharge line valve for load-less starting
- Each compressor discharge line equipped with a safety relief valve, a check valve, isolation valve, and flex connector

Compressor Motor

- NEMA rated – Open drip proof
- 1800 RPM, with 1.15 service factor
- 208 or 230/460V

Vibration Isolation System

- Compressor and motor - fully isolated from the package base by means of a four-point, heavy duty, isolation system
- Minimum of 95% isolation efficiency
- Optional seismically restrained isolators at an additional cost

Air Receiver

- Galvanized and integrally mounted with 3-valve bypass
- ASME Code stamped – National Board Certified
- Rated for a minimum 200 PSIG design pressure
- Liquid level sight glass
- Safety relief valve
- Manual drain
- Automatic timed solenoid drain valve

Dryer/Filter/Regulator System

- Dual desiccant air dryers with an integral demand based purge saving control system
- Each dryer individually sized for peak calculated demand and capable of producing a 10° F (-12° C) pressure dew point
- High efficiency coalescing pre-filter rated for 0.01 micron on each dryer with automatic drain and element change indicator
- Particulate final line filters rated for 0.01 micron on each dryer with element change indicator
- Final line regulators and safety relief valves on each dryer
- Isolation valves to permit servicing without shutting down
- Air sample port

Dew Point Hygrometer/CO Monitor

- Dew point hygrometer/CO monitor with integral chemical CO sensor - pre-piped, wired and includes remote alarm contacts
- Hygrometer sensor - ceramic type
- Accuracy - minimum of $\pm 2^\circ$ F for dew point and ± 2 PPM (at 10 PPM) for carbon monoxide
- Dew point alarm - factory set at 36° F (2° C) per NFPA 99
- CO alarm - factory set at 10 PPM
- Both set points field adjustable
- High CO and dew point indicated with visual/audible alarms

Control System

- Mounted and wired triplex control system
- NEMA 12 and U.L. labeled
- Automatic lead/lag sequencing
- Circuit breaker disconnects for each motor with external operators
- Full voltage motor starters with overload protection
- 120V control circuit transformers for each motor circuit
- Visual and audible reserve unit alarm with isolated contacts for remote alarm
- Hand-off-auto lighted selector switches
- Automatic alternation of compressors based on a first-on/first-off principle with provisions for simultaneous operation
- Automatic activation of reserve unit if required
- Visual and audible alarm indication for high discharge air temperature shutdown with isolated contacts for remote alarm
- SIGNAL 1™ – touch screen gateway

Standard Screen Displays

- | | |
|------------------------|--|
| + Air level/Runtime | + Replacement parts |
| + Alarm history | + Troubleshooting guidelines |
| + Service indicator | + Historical Trending of system status |
| + Maintenance schedule | |

- + 7” Wide TFT Graphic Touch Screen with Motion Actuated Backlit LED and Bright 65,536 (16-bit) Colors
- + Downloadable Trend Information via USB Host Port or Network Device
- + 128MB Flash Memory, 64MB DRAM
- + Built-in Ethernet Port 10/100 Base-T (RJ45)
- + Supports over 100 Communication Protocols including BACnet IP, Ethernet IP, and Modbus TCP/IP
- + Built-in Multiple Ports it can handle three (3) additional Protocols simultaneously
- + Built-in VNC server allowing remote monitoring over Ethernet/Internet network for “Real Time” monitoring of live graphics through standard browser, smart phones & mobile devices
- + Share data between HMI and Building Management systems with no additional software to implement

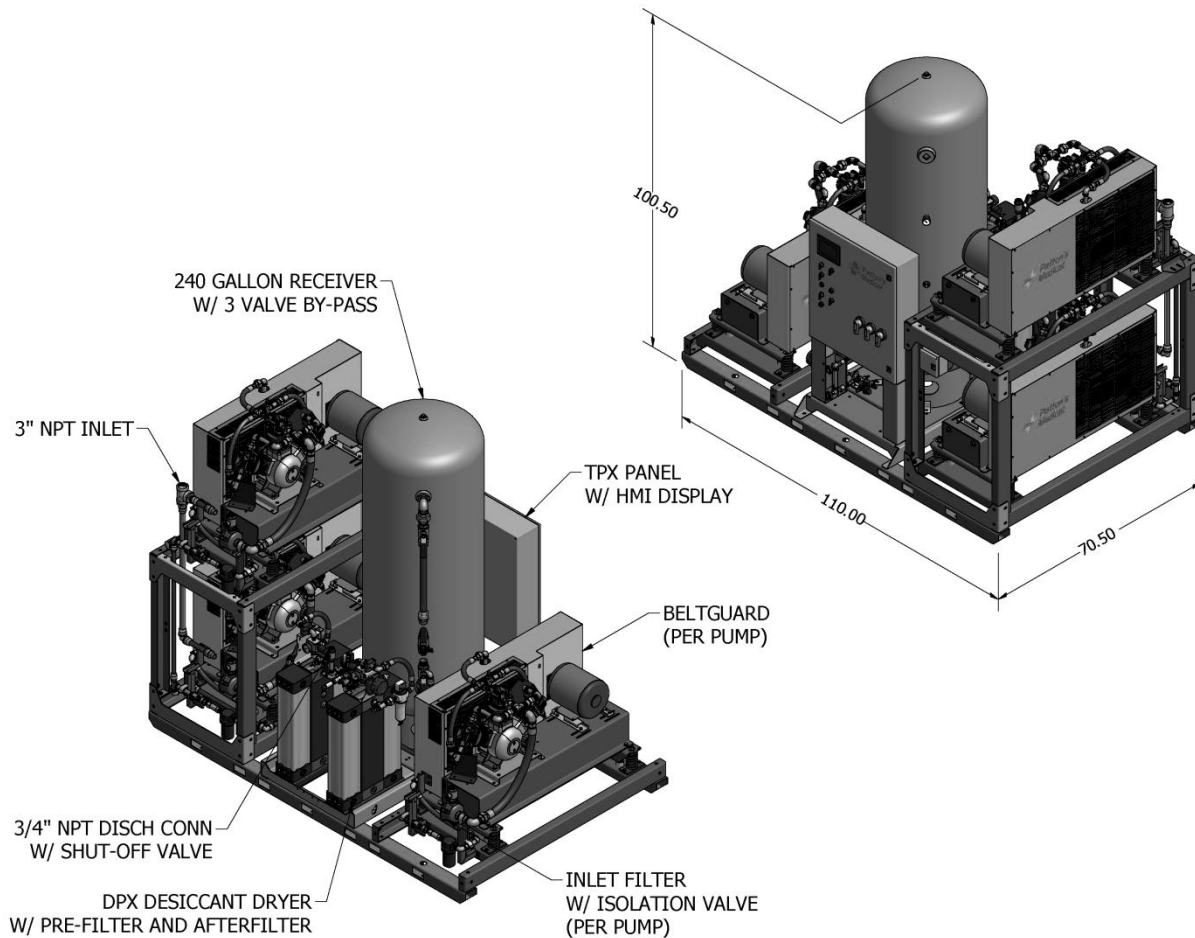

| Triplex Reciprocating Medical Air Package Specifications ¹ | | | | | | | | | | |
|---|-----|------------------------------|----------|-----------------------------|----------|--------------------------|------------|--------|--------|----------------|
| Complete Package Model No. | HP | System Capacity ² | | Package ³ BTU/HR | Receiver | Noise Level ⁴ | System FLA | | | Package Weight |
| | | 50 psig | 100 psig | | | | A 208V | B 230V | C 460V | |
| 60-35-075A | 7.5 | 58 | 52.6 | 34,124 | 240 Gal. | 81 | 74 | | | 3738 lbs. |
| 60-35-075B | | | | | | | | 67 | | |
| 60-35-075C | | | | | | | | | 33 | |

Notes:

¹ Normal Operating conditions at a maximum ambient of 105° F. Consult factory for higher ambient conditions.

² Capacities are shown as NFPA system capacities (reserve compressor on standby) and are shown in Inlet Cubic Feet per Minute (ICFM).

³ Package BTU/HR are shown with the reserve compressor on standby.

⁴ Noise levels are shown in dB(A) and reflect one compressor module running.

Statement of Warranty

Patton's Medical warrants all Medical Air packages, to be free of defects in material and workmanship under normal use for a period not to exceed thirty (30) months from date of shipment, or twenty-four (24) months from date of start-up.