

## NFPA 99 Compliant Triplex Oil-Less Reciprocating Medical Air Package 20 HP Base Mounted Modular with Desiccant Dryers

### Air Compressor Package

- Fully compliant with the latest edition of NFPA 99
- Three oil-less reciprocating air compressors with inlet filters and isolation valves
- Three motors
- ASME coded corrosion resistant air receiver with bypass
- Duplex desiccant air dryer system with purge control and piped with duplex pre-filters, after filters and regulators
- Triplex control panel with HMI control monitoring system
- All discharge air piping and fittings - ASTM B-819 copper tubing, brass and/or stainless steel
- All brazed joints are per NFPA 99
- All discharge flex connectors - braided, 304 stainless steel
- Individual compressor isolation valve
- All components completely pre-piped and pre-wired per module
- All interconnecting piping and wiring is completed and operationally tested prior to shipment
- Liquid tight conduit, fittings and junction boxes for all control and power wiring

### Air Compressor Module

- Continuous duty rated with permanently lubricated, sealed bearings
- Air-cooled single stage reciprocating type
- Corrosion resistant reed type valves with stainless steel reeds
- Compression rings and rider rings - made from a long life, fluororesin material designed for continuous duty operation
- Crankshaft constructed of a durable nodular graphite cast iron not aluminum
- Crankcase fully supported on both ends by heavy duty ball bearings permanently lubricated and sealed
- Cast aluminum alloy cylinders treated for optimum corrosion and wear resistance assure maximum heat dissipation
- Cylinder sleeves not required
- Insulated "heat cut" piston pin minimizes heat transmission from the piston wall to the piston pin needle bearing.
- Connecting rod - one-piece design for maximum reliability
- V-belt drive with means of adjustment
- OSHA approved, totally enclosed belt guard
- High discharge air temperature shutdown switch wired to the compressor control system for each compressor
- Discharge line valve for load-less starting
- Each compressor discharge line equipped with a safety relief valve, a check valve, isolation valve, and flex connector

### Compressor Motor

- NEMA rated – Open drip proof
- 1500 RPM, with 1.15 service factor
- 380V/3Ph/50Hz

### Vibration Isolation System

- Compressor and motor - fully isolated from the package base by means of a four-point, seismically restrained isolation system
- Minimum of 95% isolation efficiency

### Air Receiver

- Galvanized and integrally mounted with 3-valve bypass
- ASME Code stamped – National Board Certified
- Rated for a minimum 200 PSIG design pressure.
- Liquid level sight glass
- Safety relief valve
- Manual drain
- Automatic timed solenoid drain valve

### Dryer/Filter/Regulator System

- Dual desiccant air dryers with an integral demand based purge saving control system
- Each dryer individually sized for peak calculated demand and capable of producing a 10° F (-12° C) pressure dew point
- High efficiency coalescing pre-filter rated for 0.01 micron on each dryer with automatic drain and element change indicator
- Particulate final line filters rated for 0.01 micron mounted on each dryer with element change indicator
- Final line regulators and safety relief valves on each dryer
- Isolation valves to permit servicing without shutting down the medical air system

### Dew Point Hygrometer/CO Monitor

- Dew point hygrometer/CO monitor with integral chemical CO sensor - pre-piped, wired and includes remote alarm contacts
- Hygrometer sensor - ceramic type
- Accuracy - minimum of  $\pm 2^\circ$  F for dew point and  $\pm 2$  PPM (at 10 PPM) for carbon monoxide
- Dew point alarm - factory set at 36° F (2° C) per NFPA 99
- CO alarm - factory set at 10 PPM
- Both set points field adjustable
- High CO and dew point indicated with visual/audible alarms

### Control System

- Mounted and wired triplex control system
- NEMA 12 and U.L. labeled
- Automatic lead/lag sequencing
- Circuit breaker disconnects for each motor with external operators
- Full voltage motor starters with overload protection
- 120V control circuit transformers for each motor circuit
- Visual and audible reserve unit alarm with isolated contacts for remote alarm
- Hand-off-auto lighted selector switches
- Automatic alternation of compressors based on a first-on/first-off principle with provisions for simultaneous operation
- Automatic activation of reserve unit if required
- Visual and audible alarm indication for high discharge air temperature shutdown with isolated contacts for remote alarm
- SIGNAL 1™ – touch screen gateway

#### Standard Screen Displays

- |                        |  |
|------------------------|--|
| + Air level/Runtime    | + Replacement parts                    |
| + Alarm history        | + Troubleshooting guidelines           |
| + Service indicator    | + Historical Trending of system status |
| + Maintenance schedule |  |
- + 7" Wide TFT Graphic Touch Screen with Motion Actuated Backlit LED and Bright 65,536 (16-bit) Colors
  - + Downloadable Trend Information via USB Host Port or Network Device
  - + 128MB Flash Memory, 64MB DRAM
  - + Built-in Ethernet Port 10/100 Base-T (RJ45)
  - + Supports over 100 Communication Protocols including BACnet IP, Ethernet IP, and Modbus TCP/IP
  - + Built-in Multiple Ports it can handle three (3) additional Protocols simultaneously
  - + Built-in VNC server allowing remote monitoring over Ethernet/Internet network for "Real Time" monitoring of live graphics through standard browser, smart phones & mobile devices
  - + Share data between HMI and Building Management systems with no additional software to implement

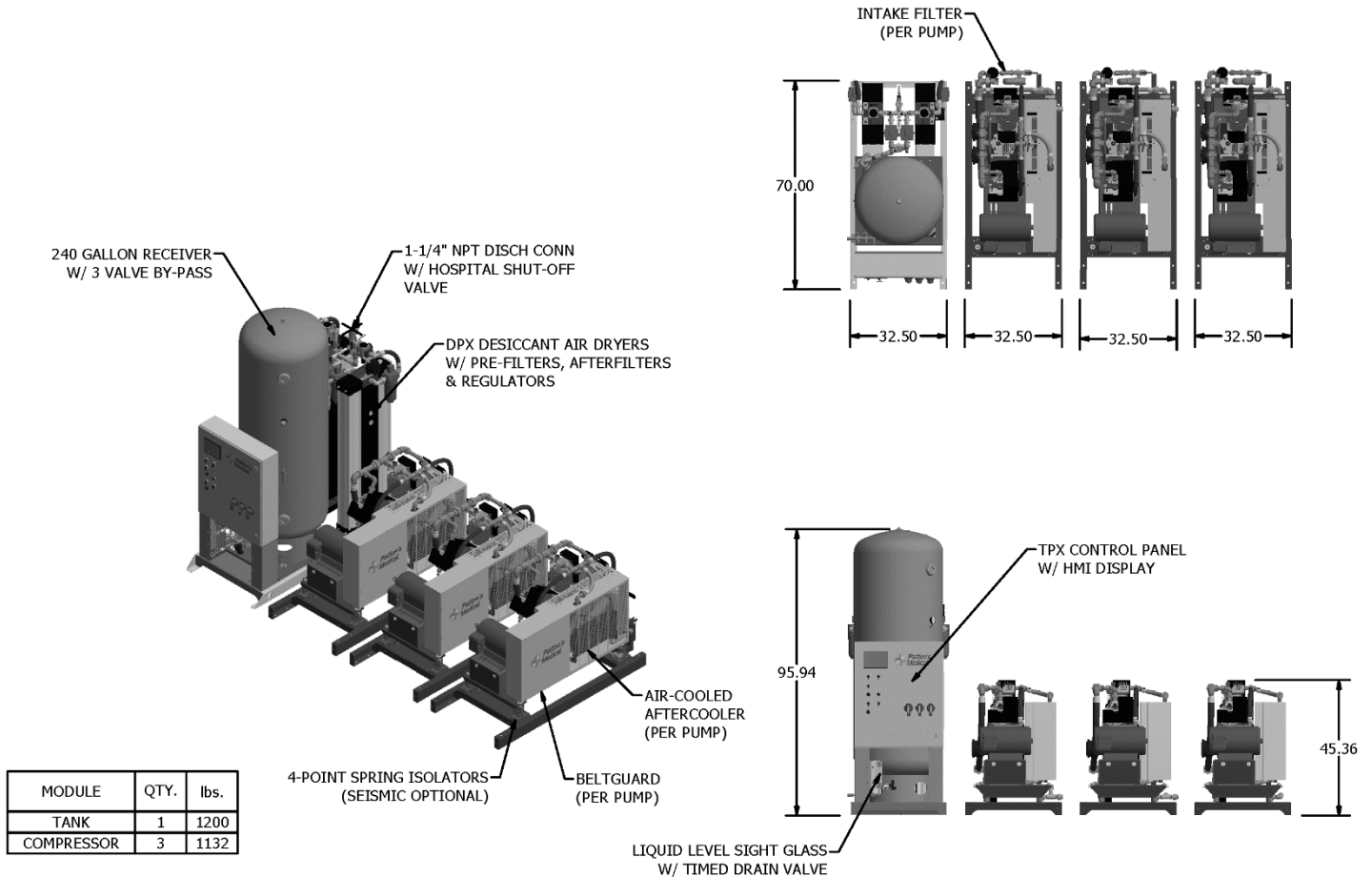

MODULE	QTY.	lbs.
TANK	1	1200
COMPRESSOR	3	1132

Triplex Reciprocating Medical Air Package Specifications <sup>1</sup>										
Complete Package Model No.	HP	System Capacity <sup>2</sup>		Package <sup>3</sup> BTU/HR	Receiver	Noise Level <sup>4</sup>	System FLA			Package Weight
		50 psig	100 psig				A 208V	B 230V	C 460V	
60-34-205A	20	156.8	132.6	89,940	240 Gal.	87	151			TOTAL 4596
60-34-205B								143		
60-34-205C									72	

**Notes:**

- <sup>1</sup> Normal Operating conditions at a maximum ambient of 105° F. Consult factory for higher ambient conditions.
- <sup>2</sup> Capacities are shown as NFPA system capacities (reserve compressor on standby) and are shown in Inlet Cubic Feet per Minute (ICFM).
- <sup>3</sup> Package BTU/HR are shown with the reserve compressor on standby.
- <sup>4</sup> Noise levels are shown in dB(A) and reflect two compressor modules running.

**Statement of Warranty**

Patton's Medical warrants all Medical Air packages, to be free of defects in material and workmanship under normal use for a period not to exceed thirty (30) months from date of shipment, or twenty-four (24) months from date of start-up.