

**Duplex “Oil-Less” Claw Lab Vacuum Package 3 HP Horizontal Tank Mount with Automatic Purge Control**
**Vacuum Package**

- Two oil-less rotary claw type vacuum pumps with automatic purge control for each pump
- Two motors
- ASME coded vacuum receiver with manual drain
- Duplex control panel with automatic lead/lag controls
- All components completely pre-piped and pre-wired to single point service connections
- Liquid tight conduit, fittings and junction boxes for all control and power wiring
- All interconnecting piping and wiring is completed and operationally tested prior to shipment

**Vacuum Pump**

- Oil-less rotary claw pump with vibration isolators
- Direct-driven through a shaft coupling
- Air-cooled
- End (ultimate) vacuum = 28.4" Hg
- Dry-running, with two claw-type, non-contacting rotors
- Sealing fluid not required
- Virtually maintenance-free operation
- Oil change required at approximately 5,000 operating hour intervals in the gearbox only
- Built-in, anti-suck-back valve mounted at the pump inlet and equipped with inlet filter for removal of particulates

**Vacuum Motor**

- NEMA rated
- C-face
- TEFC
- 3600 RPM, with 1.15 service factor
- 208 or 230/460V 3-phase

**Intake & Discharge Piping**

- Vacuum pumps are connected to a common manifold and piped to a horizontal receiver
- Inlet check valve on each pump
- Automatic isolation valve on each pump intake
- Intake Flexible connector between pump and manifold
- Discharge flexible connectors will be shipped loose

**Vacuum Receiver**

- Horizontal orientation with manual drain
- ASME Code stamped
- National Board Certified
- Rated for a minimum 200 PSIG design pressure
- Vacuum gauge

**Control System**

- Mounted and wired duplex control system
- NEMA 12 and U.L. labeled
- Automatic lead/lag sequencing
- Circuit breaker disconnects for each motor with external operators
- Full voltage motor starters and contactors with overload protection
- 120V control circuit transformers for each motor circuit
- Visual and audible reserve unit alarm with isolated contacts for remote alarm
- Hand-off-auto selector switches
- Automatic alternation of all vacuum pumps based on a first-on/first-off principle with provisions for simultaneous operation if required
- Automatic activation of reserve unit if required
- Visual and audible alarm indication for high discharge temperature shutdown with isolated contacts for remote alarm
- SIGNAL 1™ – touch screen gateway

Standard Screen displays

- |                         |                                        |
|-------------------------|----------------------------------------|
| + Vacuum level /Runtime | + Replacement parts                    |
| + Alarm history         | + Troubleshooting guidelines           |
| + Service indicator     | + Historical trending of system status |
| + Maintenance schedule  |                                        |

- + 7" Wide TFT Graphic Touch Screen with Motion Actuated Backlit LED
- + Bright 65,536 (16-bit) Colors
- + Downloadable Trend Information via USB Host Port or Network Device
- + 128MB Flash Memory, 64MB DRAM
- + Built-in Ethernet Port 10/100 Base-T (RJ45)
- + Supports over 100 Communication Protocols including BACnet IP, Ethernet IP, and Modbus TCP/IP
- + With Multiple Ports it can handle three (3) additional Protocols simultaneously
- + Built-in VNC server allowing remote monitoring over Ethernet/Internet network for “Real Time” monitoring of live graphics through standard browser, smart phones and mobile devices.
- + Share data between HMI and Building Management systems with no additional software to implement.

**Automatic Purge Control**

- Each pump intake is equipped with a auto purge valve and automatic isolation valve
- Minimum run and purge cycle are controlled via SIGNAL 1 purge control function
- Selection of automatic purge, manual purge, or purge off
- 15 minute purge cycle per pump

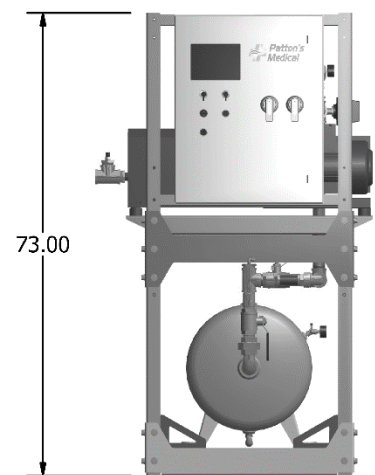
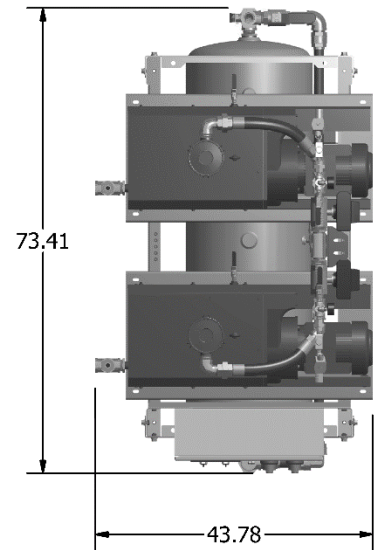
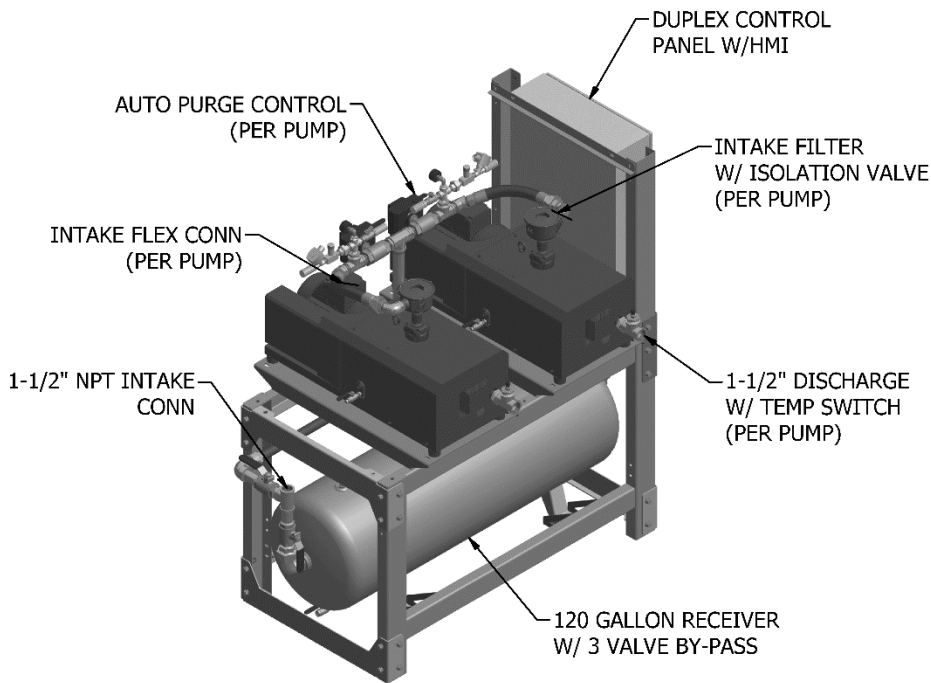

Duplex Claw Lab Vacuum Package Specifications <sup>1</sup>										
System Model No.	HP	Capacity @19" Hg <sup>2</sup>		Package BTU/HR <sup>3</sup>	Receiver Gallon	Noise Level <sup>3</sup>	System FLA			Package Weight
		Pump (SCFM)	System (SCFM)				208V	230V	460V	
75L-21-033A	3	21	42	15,300	120	72	21	20	9	1,508
75L-21-033B										
75L-21-033C										

Notes:

<sup>1</sup> Normal Operating conditions at a maximum ambient of 105° F. Consult factory for higher ambient conditions.

<sup>2</sup> Package BTU/HR are shown with all pumps running.

<sup>3</sup> Noise levels are shown in dB(A) with all pumps running.

**Statement of Warranty**

Patton's Medical warrants all Medical Vacuum packages, to be free of defects in material and workmanship under normal use for a period not to exceed thirty (30) months from date of shipment, or twenty-four (24) months from date of start-up.