

Duplex “Oil-Less” Scroll Lab Air Package 7.5 HP Vertical Tank Mounted with Single Point Connection and Desiccant Dryers

Air Compressor Package

- Two "oil-less" scroll air compressor modules with inlet filters
- ASME coded corrosion resistant air receiver with bypass
- Duplex desiccant air dryer system with purge control and piped with duplex pre-filters, after filters and regulators
- Duplex control panel with HMI control monitoring system
- All discharge air piping and fittings - ASTM B-819 copper tubing, brass and/or stainless steel
- All discharge flex connectors - braided, 304 stainless steel
- Individual compressor isolation valve
- All components completely pre-piped and pre-wired to single point service connections
- All interconnecting piping and wiring is completed and operationally tested prior to shipment
- Liquid tight conduit, fittings and junction boxes for all control and power wiring

Air Compressor Module

- Continuous duty rated
- Air-cooled single stage scroll type
- Constructed of one fixed and one orbiting scroll sealed with PTFE tip seals between the scroll halves
- Rated for 120 psig discharge pressure
- Protected from dust or contamination with a two-part face seal
- Drive/Orbiting bearings - grease filled - 10,000 hour maintenance
- Scroll housing constructed of die cast aluminum
- Integral cooling and air ducting for maximum heat dissipation
- Stationary pumps and motor for ease of alignment
- Air-cooled aftercoolers for each compressor module with maximum approach temperature of 15° F and automatic solenoid drain valves
- V-belt arrangement with means of adjustment
- OSHA approved, totally enclosed belt guard
- High discharge air temperature shutdown switch wired to the compressor control system for each compressor
- Discharge line valve for load-less starting
- Each compressor discharge line equipped with a safety relief valve, a check valve, isolation valve, and flex connector

Compressor Motor

- NEMA rated – Open drip proof
- 3600 RPM, with 1.15 service factor
- 208 or 230/460V

Vibration Isolation System

- Compressor and motor - fully isolated from the package base by means of a four-point, heavy duty, isolation system
- Minimum of 95% isolation efficiency
- Optional seismically restrained isolators at an additional cost

Dryer/Filter/Regulator System

- Dual desiccant air dryers with an integral demand-based purge saving control system (**sized for all pumps running**)
- Each dryer individually sized for peak calculated demand and capable of producing a -40° F (-40° C) pressure dew point
- High efficiency coalescing pre-filter rated for 0.01 micron on each dryer with automatic drain and element change indicator
- Particulate final line filters rated for 0.01 micron on each dryer with element change indicator
- Final line regulators and safety relief valves on each dryer
- Isolation valves to permit servicing without shutting down the medical air system
- Air sample port

Air Receiver

- Corrosion resistant and integrally mounted with 3-valve bypass
- ASME Code stamped and National Board Certified
- Rated for a minimum 200 PSIG design pressure
- Liquid level sight glass
- Safety relief valve
- Manual drain and Automatic timed solenoid drain valve
- Pressure Gauge

Dew Point Hygrometer

- Dew point hygrometer - pre-piped, wired and includes remote alarm contacts
- Hygrometer sensor - ceramic type
- Accuracy - minimum of ± 2° F for dew point
- Dew point alarm - factory set at 36° F (2° C) per NFPA 99
- Set points field adjustable
- High dew point indicated with visual/audible alarms

System Health

- Monitoring and Trending of key components to provide notification of potential issue with the Health of the System
- Pressure monitoring
- Current monitoring for each motor
- Ambient Temperature monitoring
- Dew Point monitoring

Control System

- Mounted and wired duplex control system
- NEMA 12 and UL 508A labeled
- Automatic lead/lag sequencing
- Circuit breaker disconnects for each motor with external operators
- Full voltage motor starters with overload protection
- 120V control circuit transformers for each motor circuit
- Visual and audible reserve unit alarm with isolated contacts for remote alarm
- Hand-off-auto selector switches for reliable back-up
- Automatic alternation of compressors based on a first-on/first-off principle with provisions for simultaneous operation
- Automatic activation of reserve unit if required
- Visual and audible alarm indication for high discharge air temperature shutdown with isolated contacts for remote alarm
- SIGNAL 1™ – touch screen gateway

Standard Screen Displays

- | | |
|------------------------|--|
| + Air level/Runtime | + Replacement parts |
| + Alarm history | + Troubleshooting guidelines |
| + Service Indicator | + Historical trending of system status |
| + Maintenance Schedule | + System Health |

- 7" Wide TFT Graphic Touch Screen with Motion Actuated Backlit LED and Bright 65,536 (16-bit) Colors
- Downloadable Trend Information via USB Host Port or Network Device
- 128MB Flash Memory, 64MB DRAM
- Built-in Ethernet Port 10/100 Base-T (RJ45)
- Supports over 100 Communication Protocols including Ethernet IP, and Modbus TCP/IP
- BACnet IP communication available
- Built-in VNC server allowing remote monitoring of live graphics through standard browser, smart phones & mobile devices
- Share data between HMI and Building Management systems

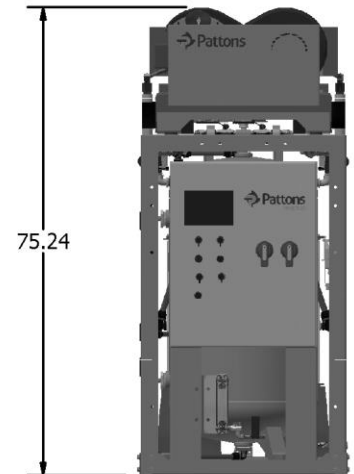
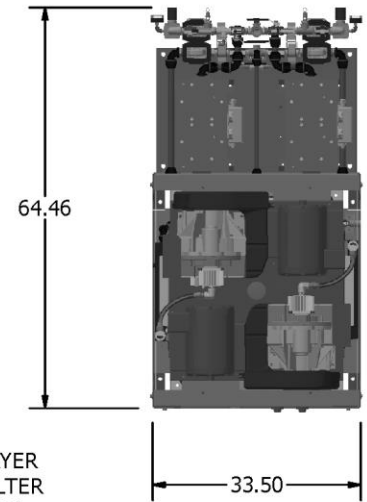
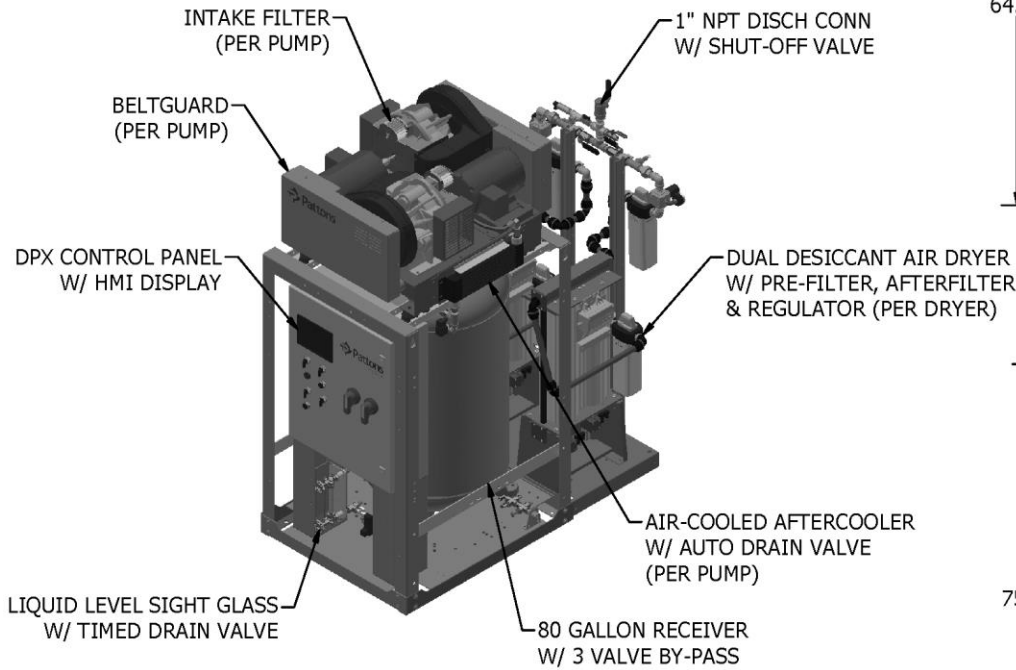

Duplex Scroll Lab Air Package Specifications ¹										
Model Number	HP	System Capacity ²			Package BTU/HR ³	Noise Level ⁴	System FLA			Weight (pounds)
		50 PSIG	100 PSIG	120 PSIG			208V (A)	230V (B)	460V (C)	
68-22-072(A/B/C)X-L0000A0-000	7.5	50.4	48	42.4	34,124	75	41	37	19	1,304

Notes:

¹ Normal Operating conditions at a maximum ambient of 105° F. Consult factory for higher ambient conditions.

² Capacities are shown as with all pumps running and are shown in Inlet Cubic Feet per Minute (ICFM).

³ Package BTU/HR are shown with all pumps running.

⁴ Noise levels are shown in dB(A) and reflect two compressor modules running.

Statement of Warranty

Patton's Medical warrants all Lab Air packages, to be free of defects in material and workmanship under normal use for a period not to exceed thirty (30) months from date of shipment, or twenty-four (24) months from date of start-up.