

**Modular Medical Vacuum Bacterial Filter Modules**

**Overview**

- Compliant with NFPA 99:2018 Health Care Facilities Code
- Particulate removal >99.995% efficiency
- Minimizes microbial contamination of vacuum pump oil and surrounding environment.
- Isolation Valve before and after for isolation during service.
- Equipped with pressure differential gauge for visual indication of service filter
- Glass drain flask for easy removal and sterilization

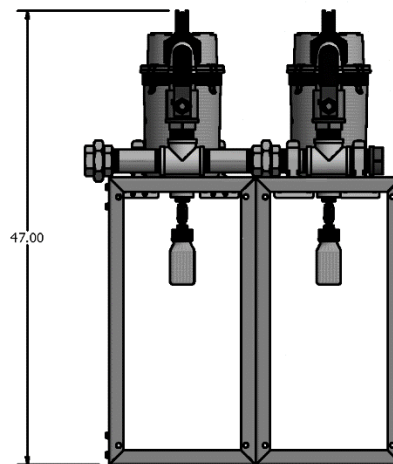
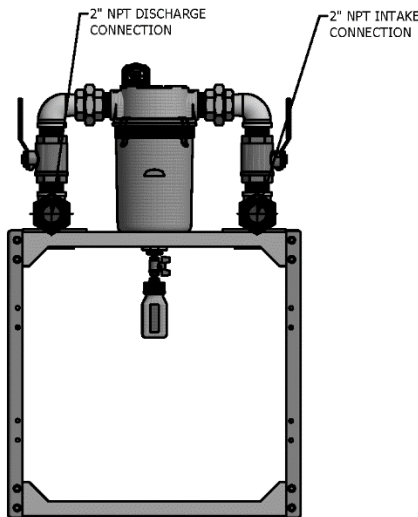
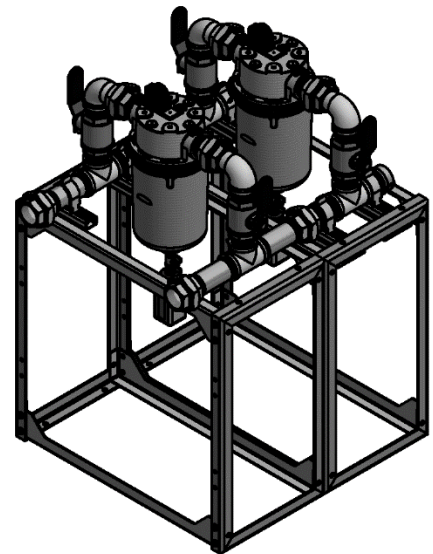
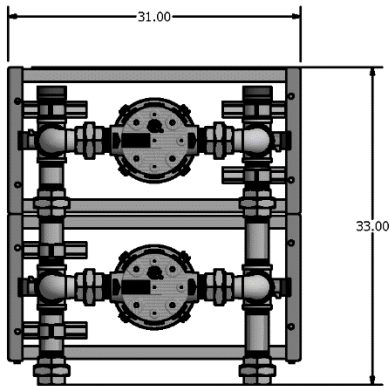

Medical Vacuum Filter Modules								
Model Number	# OF FILTERS	SYSTEM SCFM <sup>1</sup>	Dimension (Inch)			FLANGE CONNECTION (Inch)		WEIGHT (LBS.)
			H	L	W	INLET	OUTLET	
58-24-200	2	140	47	33	31	2"	2"	135

<sup>1</sup> Capacities are shown as NFPA system capacities (one filter on standby)