

Modular Medical Vacuum Bacterial Filter Modules

Overview

- Compliant with NFPA 99:2018 Health Care Facilities Code
- Particulate removal >99.995% efficiency
- Minimizes microbial contamination of vacuum pump oil and surrounding environment.
- Isolation Valve before and after for isolation during service.
- Equipped with pressure differential gauge for visual indication of service filter
- Glass drain flask for easy removal and sterilization

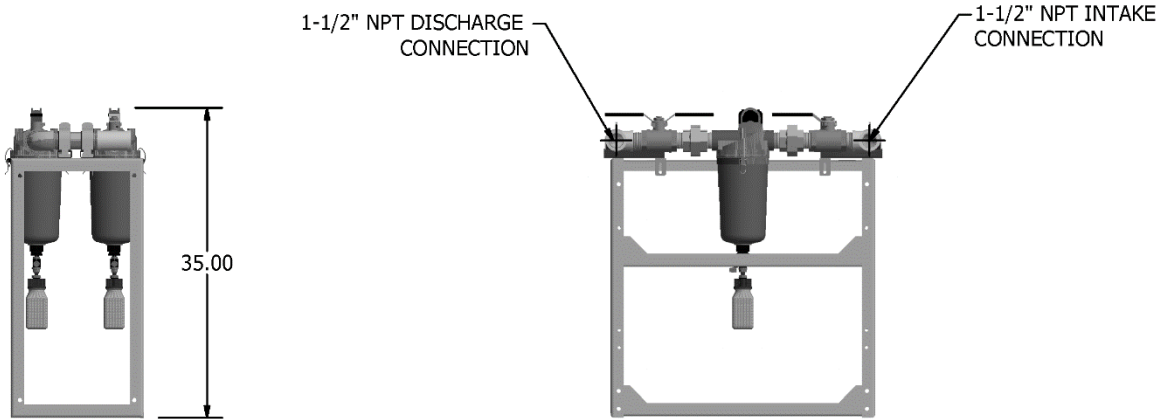
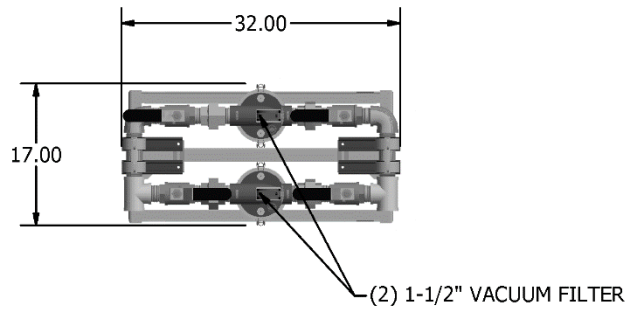
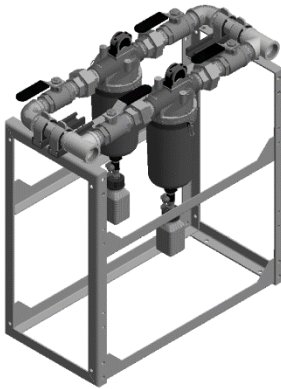

Medical Vacuum Filter Modules								
Model Number	# OF FILTERS	SYSTEM SCFM ¹	Dimension (Inch)			FLANGE CONNECTION (Inch)		WEIGHT (LBS.)
			H	L	W	INLET	OUTLET	
58-24-150	2	45	35	32	17	1-1/2"	1-1/2"	95

¹ Capacities are shown as NFPA system capacities (one filter on standby)