

**NFPA 99 Compliant Pentaplex expandable to Octaplex “Oil-Less” Scroll Medical Air Package  
20 HP Base Mounted Modular with Desiccant Dryers**
**Air Compressor Package**

- Fully compliant with the latest edition of NFPA 99
- Five "oil-less" scroll air compressor modules with inlet filter, isolation valve and high inlet vacuum switch for each
- ASME coded corrosion resistant air receiver with bypass
- Duplex desiccant air dryer system with purge control and piped with duplex pre-filters, after filters and regulators
- Octaplex control panel with HMI control monitoring system
- All discharge air piping and fittings - ASTM B-819 copper tubing, brass and/or stainless steel
- All discharge flex connectors - braided, 304 stainless steel
- Individual compressor isolation valve
- All components completely pre-piped and pre-wired per module
- Entire package is operationally tested prior to shipment
- Liquid tight conduit, fittings and junction boxes for all control and power wiring

**Air Compressor Module**

- Continuous duty rated
- Air-cooled single stage scroll type
- Constructed of one fixed and one orbiting scroll sealed with PTFE tip seals between the scroll halves
- Rated for 120 psig discharge pressure
- Protected from dust or contamination with a two-part face seal
- Drive/Orbiting bearings - grease filled - 10,000hour maintenance
- Scroll housing constructed of die cast aluminum
- Integral cooling and air ducting for maximum heat dissipation
- Stationary pumps and motor for ease of alignment
- Air-cooled aftercoolers for each compressor module with maximum approach temperature of 15° F and automatic solenoid drain valves
- Serpentine v-belt arrangement with idler pulley adjustment
- OSHA approved, totally enclosed belt guard
- High discharge air temperature shutdown switch wired to the compressor control system for each compressor
- Discharge line valve for load-less starting
- Each compressor discharge line equipped with a safety relief valve, a check valve, isolation valve, and flex connector

**Compressor Motor**

- NEMA rated – Open drip proof
- 3600 RPM, with 1.15 service factor
- 208 or 230/460V

**Vibration Isolation System**

- Compressor and motor - fully isolated from the package base by means of a four-point, heavy duty, isolation system
- Minimum of 95% isolation efficiency
- Optional seismically restrained isolators at an additional cost

**Dryer/Filter/Regulator System**

- Dual desiccant air dryers with an integral demand-based purge saving control system
- Each dryer individually sized for peak calculated demand and capable of producing a 10° F (-12° C) pressure dew point
- High efficiency coalescing pre-filter rated for 0.01 micron on each dryer with automatic drain and element change indicator
- Particulate final line filters rated for 0.01 micron on each dryer with element change indicator
- Final line regulators and safety relief valves on each dryer
- Isolation valves to permit servicing without shutting down the medical air system
- Air sample port

**Air Receiver**

- Corrosion resistant and integrally mounted with 3-valve bypass
- ASME Code stamped and National Board Certified
- Rated for a minimum 200 PSIG design pressure
- Liquid level sight glass
- Safety relief valve
- Manual drain and Automatic timed solenoid drain valve
- Pressure Gauge

**Dew Point Hygrometer/CO Monitor**

- Dew point hygrometer/CO monitor with integral chemical CO sensor - pre-piped, wired and includes remote alarm contacts
- Hygrometer sensor - ceramic type
- Accuracy - minimum of ± 2° F for dew point and ± 2 PPM (at 10 PPM) for carbon monoxide
- Dew point alarm - factory set at 36° F (2° C) per NFPA 99
- CO alarm - factory set at 10 PPM
- Both set points field adjustable
- High CO and dew point indicated with visual/audible alarms

**System Health**

- Monitoring and Trending of key components to provide notification of potential issue with the Health of the System
- Pressure monitoring
- Current monitoring for each motor
- Ambient Temperature monitoring
- CO monitoring
- Dew Point monitoring

**Control System**

- Mounted and wired octaplex control system
- NEMA 12 and UL 508A labeled
- Automatic lead/lag sequencing
- Circuit breaker disconnects for each motor (one external disconnect)
- Full voltage motor starters with overload protection
- 120V control circuit transformers for each motor circuit
- Visual and audible reserve unit alarm with isolated contacts for remote alarm
- Hand-off-auto selector switches for reliable back-up
- Automatic alternation of compressors based on a first-on/first-off principle with provisions for simultaneous operation
- Automatic activation of reserve unit if required
- Visual and audible alarm indication for high discharge air temperature shutdown with isolated contacts for remote alarm
- SIGNAL 1™ – touch screen gateway

**Standard Screen Displays**

- |                        |  |
|------------------------|--|
| + Air level/Runtime    | + Replacement parts                    |
| + Alarm history        | + Troubleshooting guidelines           |
| + Service Indicator    | + Historical trending of system status |
| + Maintenance Schedule | + System Health                        |

- 7" Wide TFT Graphic Touch Screen with Motion Actuated Backlit LED and Bright 65,536 (16-bit) Colors
- Downloadable Trend Information via USB Host Port or Network Device
- 128MB Flash Memory, 64MB DRAM
- Built-in Ethernet Port 10/100 Base-T (RJ45)
- Supports over 100 Communication Protocols including Ethernet IP, and Modbus TCP/IP
- Built-in VNC server allowing remote monitoring of live graphics through standard browser, smart phones & mobile devices
- Share data between HMI and Building Management systems

## SPECIFICATION

62-54-2000

62-54-2040

62-54-2050

62-54-2070

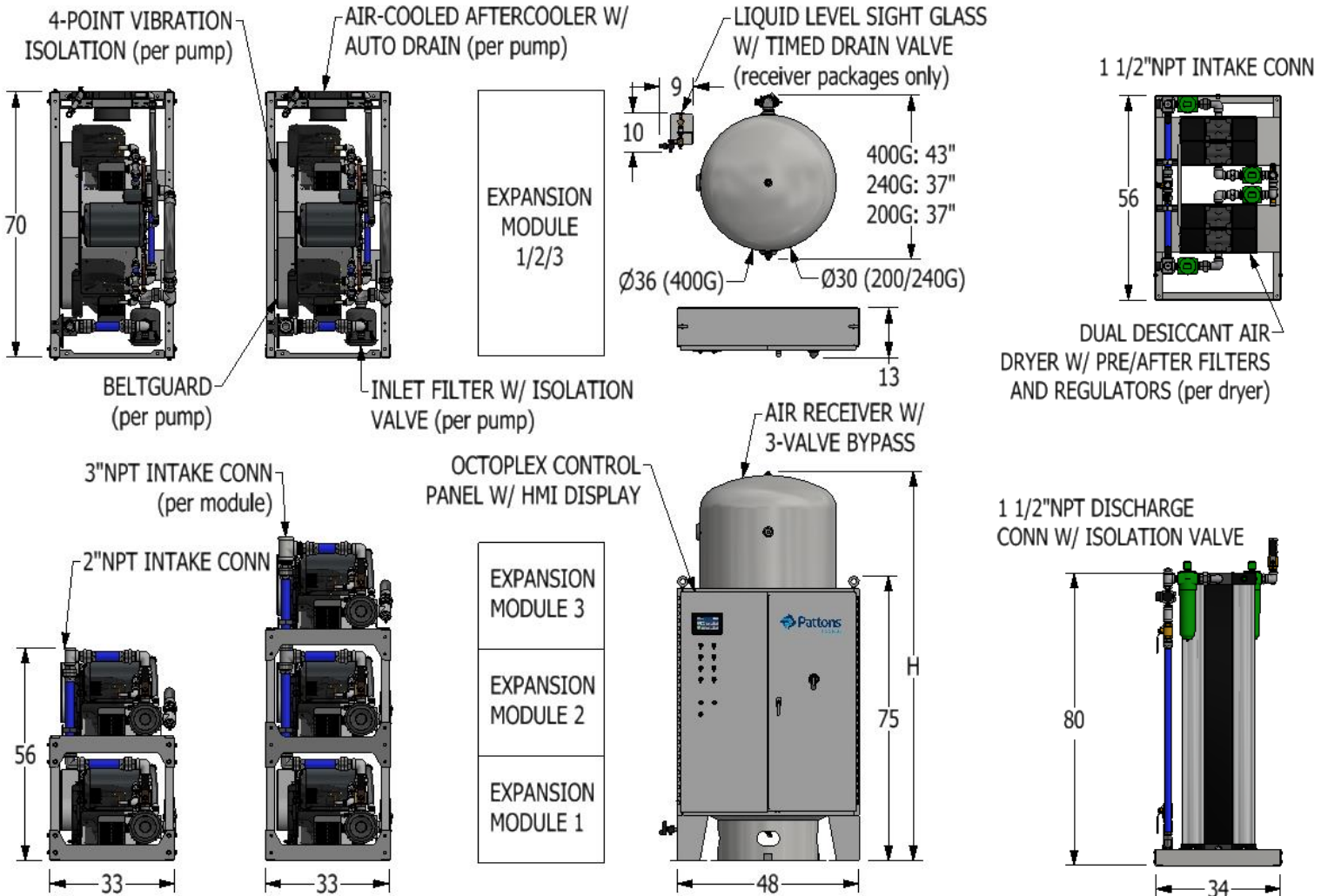

### Pentaplex expandable to Octaplex Scroll Medical Air Package Specifications<sup>1</sup>

Model Number	HP	System Capacity <sup>2</sup>		Package BTU/HR <sup>3</sup>	Noise Level <sup>4</sup>	System FLA			Receiver Size (gallons)	Receiver Height (H) (inches)	Package Weight (pounds)
		50 psig	110 psig			208V (A)	230 (B)	460V (C)			
62-54-2000(A/B/C)	20								0	0	5,312 (7,525) <sup>5</sup>
62-54-2040(A/B/C)		278 (487) <sup>5</sup>	256 (448) <sup>5</sup>	203,736 (356,538) <sup>5</sup>	85 (90) <sup>5</sup>	255 (414) <sup>5</sup>	229 (381) <sup>5</sup>	115 (191) <sup>5</sup>	200	85	5,817 (8,030) <sup>5</sup>
62-54-2050(A/B/C)									240	96	5,967 (8,180) <sup>5</sup>
62-54-2070(A/B/C)									400	103	6,182 (8,395) <sup>5</sup>

#### Notes:

<sup>1</sup> Normal Operating conditions at a maximum ambient of 105° F. Consult factory for higher ambient conditions.

<sup>2</sup> Capacities are shown as NFPA system capacities (reserve compressor on standby) and are shown in Inlet Cubic Feet per Minute (ICFM).

<sup>3</sup> Package BTU/HR are shown with the reserve compressor on standby.

<sup>4</sup> Noise levels are shown in dB(A) and reflect two compressor modules running.

<sup>5</sup> Top numbers are based on Pentaplex and numbers in "(xxx)" are based on Octaplex.

#### Statement of Warranty

Patton's Medical warrants all Medical Air packages, to be free of defects in material and workmanship under normal use for a period not to exceed thirty (30) months from date of shipment, or twenty-four (24) months from date of start-up.