

Single Zone Valve Box w/ sensor provision (2" - 3") - NFPA

General Specifications:

Zone valve boxes shall be a Series 1.

Each zone valve box shall comply with NFPA® 99 and shall consist of the following components: A recessed steel valve box which can accommodate one quarter turn isolation valve with tube extensions, an aluminum frame, and a snap-out removable opaque window and sensor provision consisting of one terminal block and one street elbow for each valve. Gauges and sensors are optional.



The zone valve box shall be constructed of 18 gauge steel complete with a baked white enamel finish. The box shall be equipped with two adjustable steel brackets for the purpose of mounting the box to the structural support. The steel brackets shall accommodate various finished wall thicknesses between 3/8" [9.5 mm] and 1-3/16" [30 mm] and shall be field adjustable.

The frame assembly shall be constructed of anodized aluminum and shall be mounted to the back box assembly by standard tapping screws as provided. The opaque window shall be equipped with a center mounted ring to allow the window to be removed from the valve box frame.

Access to the zone shut-off valve shall be by merely pulling the ring assembly to remove the window from the frame. The window can be reinstalled without the use of tools only after the valve handle have been returned to the open position.

The window shall be marked to prohibit unauthorized persons from tampering with the valves with the following silk-screen caution:

"MEDICAL GAS ISOLATION VALVE CLOSE ONLY IN EMERGENCY"

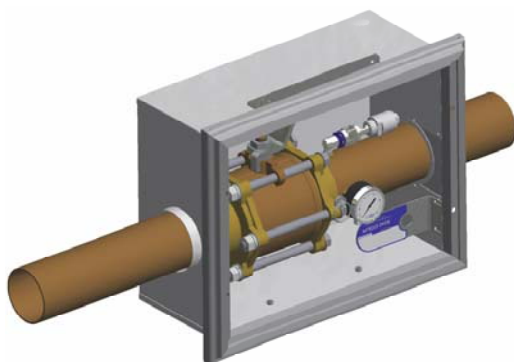

The valve shall be 3 piece ball-type with a full port design. All valves shall be serviceable in the line, supplied clean and prepared for oxygen service. The valve shall have a bronze body and a blow-out proof stem. The valve ball shall be bronze chrome plated and the seats and packing shall be Reinforced Teflon (PTFE). The valve shall also have a continuous pressure of up to 600 psi and vacuum service to 29" Hg.

The valve shall be sized 2" to 3" and operated by a lever-type handle requiring only a quarter turn from a fully open position to a fully closed position.

All valves shall be equipped with type "K" copper pipe extensions of sufficient length to protrude beyond the sides of the box.

Each valve shall be supplied with an identification bracket for the purpose of applying an approved medical gas identification label. A package of labels shall be supplied with each valve box assembly for application by the installer.

Technical Specifications:

Single Valve Box Shown

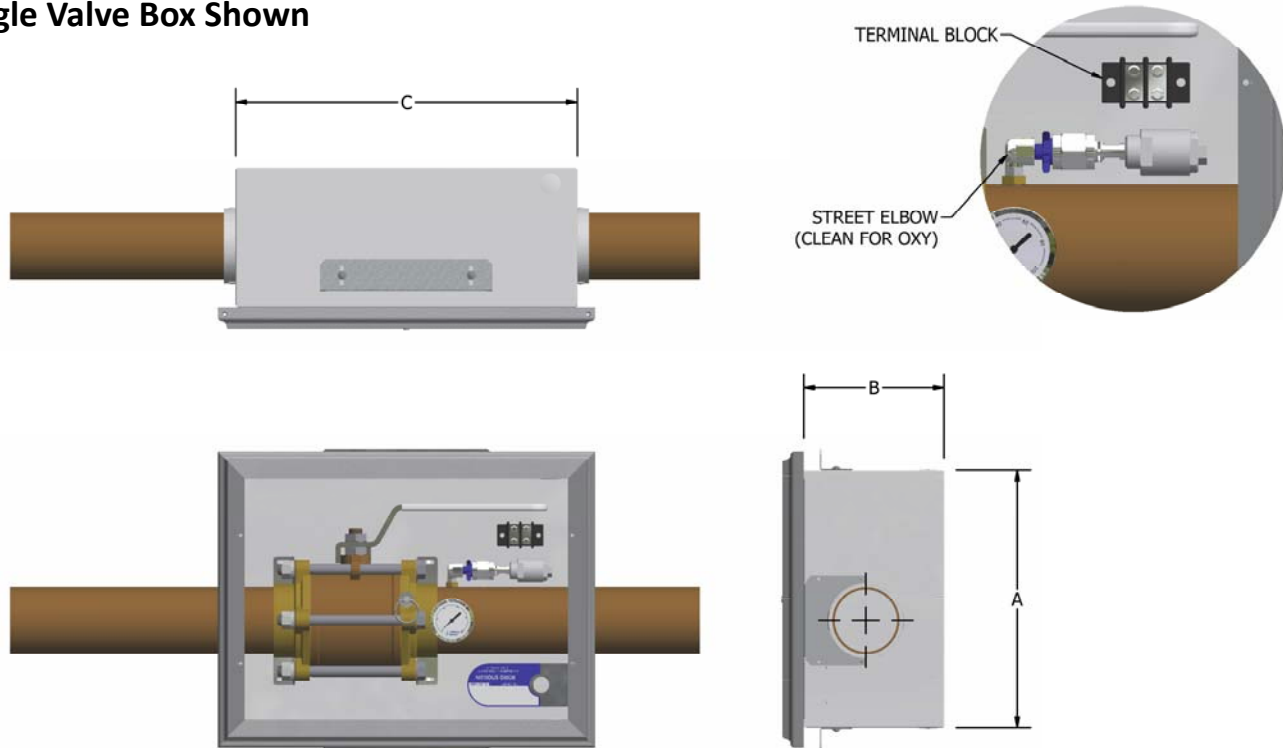

Zone Valve Box Dimensions				
Model	Valve Size	Dimension A	Dimension B	Dimension C
1 valve box	2"	12"	3-7/8"	12"
1 valve box	2-1/2"	12"	6-1/2"	15-3/4"
1 valve box	3"	12"	6-1/2"	15-3/4"

Note: All valves are full port.
 The 2" valve in a single zone valve box will be in a 3-7/8" deep box.
 The 2-1/2" - 3" valve in a single zone valve box will be in a 6-1/2" deep box.

- OXY: 27-03-001-002
- MED AIR: 27-01-001-002
- N2O: 27-02-001-002
- CO2: 27-04-001-002
- NIT: 27-05-001-002
- Instrument Air: 27-06-001-002
- HELIUM: 27-07-001-002
- VACUUM: 27-08-001-002
- WAG: 27-09-001-002

Model Numbers

ZVB-NSXX

N = Without Gauge

Replace XX with the following to indicate Valve size(s) required:

2"	= 20
2-1/2"	= 25
3"	= 30

Example: Single box with Opaque Window, a 2" valve, without gauge = ZVB-NS20
Gauge Available Separately: PM-GA2-XXX