

Vacuum Switch - Vacuum

General Specifications:

The Vacuum Switch for the medical gas alarm system will incorporate a U.L. Listed single pole double throw snap-action micro switch. The pressure switch will be prewired with three color coded leads. Normally open or Normally closed circuitry will be field-selected to be compatible with the medical gas alarm design. Electrical rating will be 10 amps at 120 volt AC.

The vacuum switch will be tested up to 30" Hg with an adjustable range of .8" to 29" Hg, present at 12" Hg for the alarm condition.

The switch enclosure will have a Nema 4 water tight housing with mounting bracket, 1/4" FNPT bottom inlet gas service line connection, and 3/4" FNPT top inlet conduit.

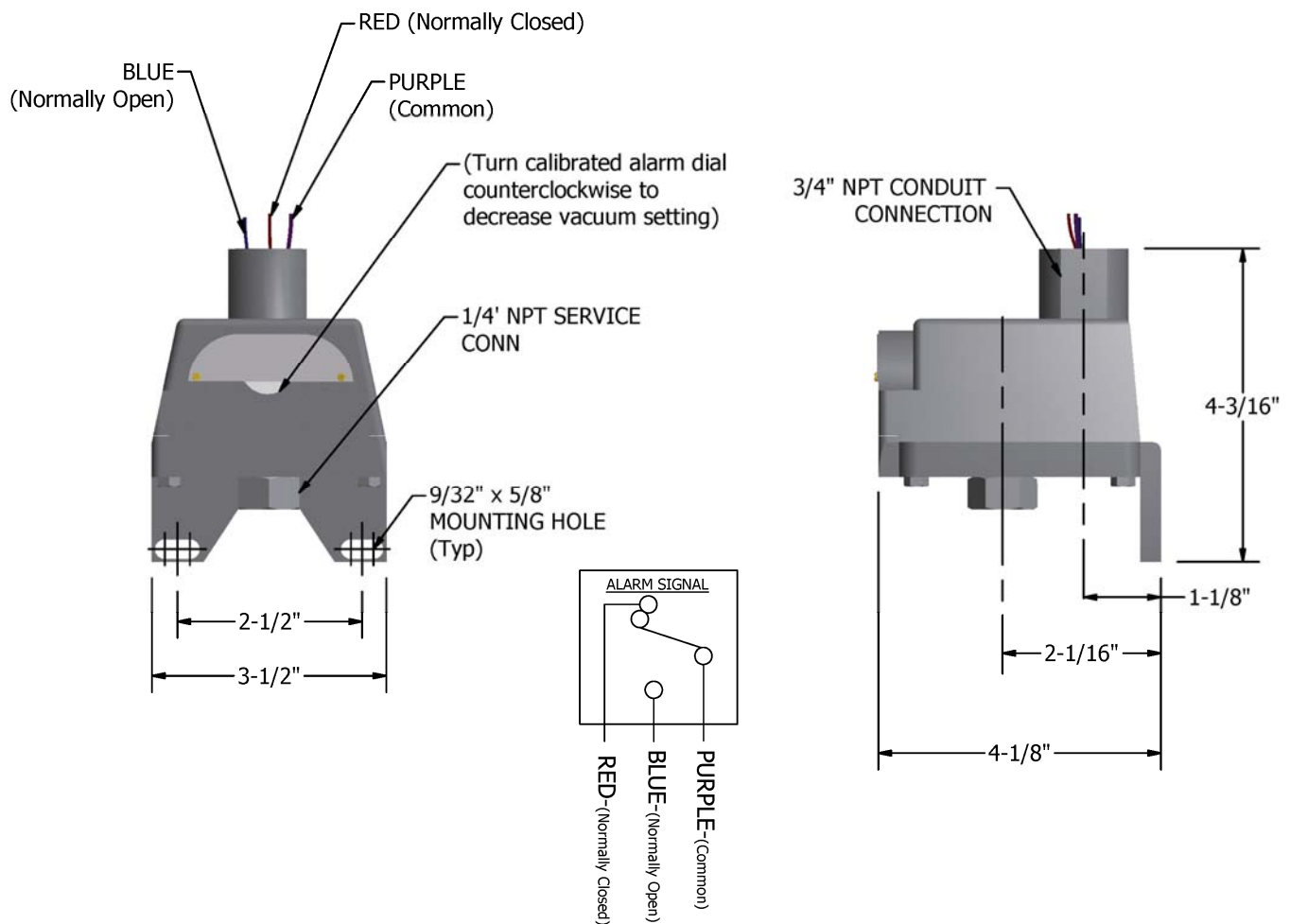

Vacuum Switch	
M1-PRSW-N-VAC	Vacuum