

Pressure Switch - Oxygen

General Specifications:

The Pressure Switch for the medical gas alarm system will incorporate a U.L. Listed single pole double throw snap-action micro switch. The pressure switch will be prewired with six color coded leads. Normally open or Normally closed circuitry will be field-selected to be compatible with the medical gas alarm design. Electrical rating will be 10 amps at 120 volt AC.

The pressure switch will be tested at 150 psi with an adjustable range of .5 to 80 psi and have external calibration dials with tamper-proof cover. Factory settings will be 40 psi and 60 psi for pressure gases.

The switch enclosure will have a Nema 4 water tight housing with mounting bracket, 1/4" FNPT bottom inlet gas service line connection, and 3/4" FNPT top inlet conduit.

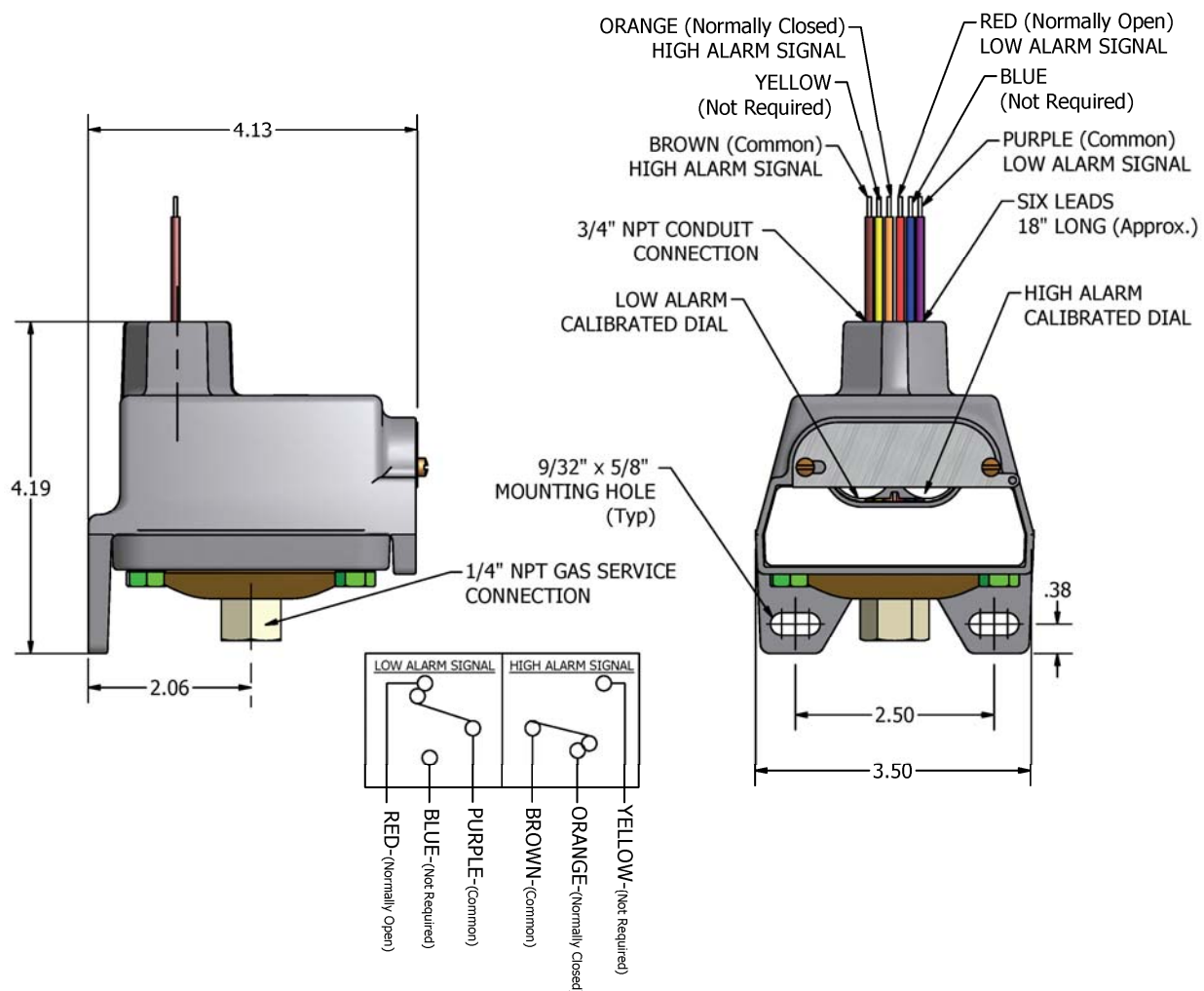

Pressure Switch	
M1-PRSW-N-OXY	Oxygen

Statement of Warranty

Patton's Medical warrants all Products, to be free of defects in material and workmanship under normal use for a period not to exceed twenty-four (24) months from date of shipment..