

# Pressure Switch - Instrument Air

## General Specifications:

The Pressure Switch for the medical gas alarm system will incorporate a U.L. Listed single pole double throw snap-action switch. Electrical connections are made through a 1/2" conduit connection to screw terminals on the switch. The switch may be wired Normally open or Normally closed. Electrical rating will be 10 amps at 120 volt AC.

The pressure switch has a proof pressure of 1000 psi with an adjustable range of 10 to 230 psi decreasing pressure or 11 to 250 psi increasing pressure. Provide one switch for the high pressure alarm signal and one for the low pressure alarm signal.

The switch enclosure will have a Nema 4 water tight housing with a 1/4" NPT bottom inlet gas service line connection, and 1/2" NPT top inlet conduit.

The Pressure Switch is UL Listed and CSA Approved.

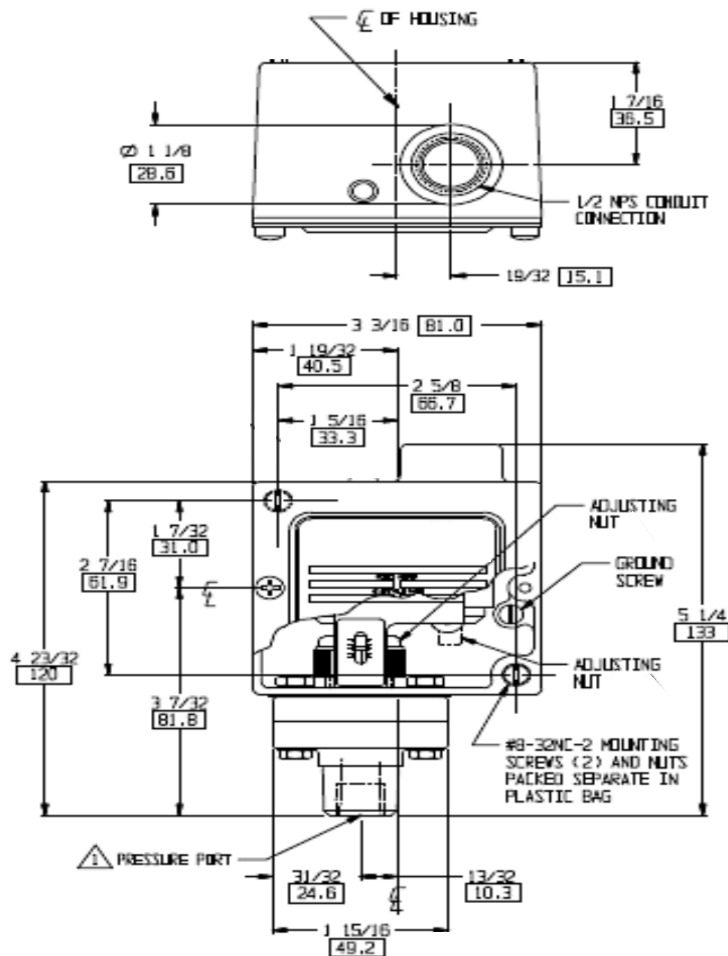
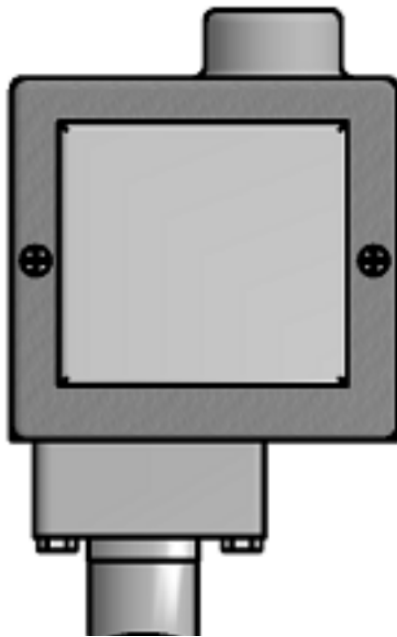

Pressure Switch	
M1-PRSW-N-IA	Instrument Air