

NFPA 99 Compliant Quad Lubricated Rotary Vane Medical Vacuum Package 20 HP Base Mounted with Single Point Connection

Vacuum Package

- Fully compliant with the latest edition of NFPA 99
- Four lubricated rotary vane type vacuum pumps with inlet filter and isolation valve for each
- Four motors
- ASME coded vertical air receiver with bypass and manual drain
- Quad control panel with automatic lead/lag controls
- All components completely pre-piped and pre-wired to single point service connections
- Vibration isolation mountings
- Liquid tight conduit, fittings and junction boxes for all control and power wiring
- All interconnecting piping and wiring is completed and operationally tested prior to shipment

Vacuum Pump

- Lubricated rotary vane pump
- Three non-metallic, non-asbestos vanes with minimum life of 30,000 hrs.
- Direct-driven through a shaft coupling
- Air-cooled
- End (ultimate) vacuum = 29.3" Hg
- Integral, fully recirculating oil supply
- Spin-on oil filter
- High discharge temperature switch
- Oil drain valve assembly with temperature gauge
- Uses SAE 30 weight oil
- Integral oil separation system with three stage oil and smoke eliminators capable of removing 99.9+% of particles from the exhaust gas stream
- Built-in, anti-suck-back valve mounted at the pump inlet
- Inlet filter for removal of particulates

Vacuum Motor

- NEMA rated
- C-face
- TEFC
- 208 or 230/460V 3-phase

Intake Piping

- Vacuum pumps are connected to a common manifold and piped to a vertical receiver
- Inlet check valve on each pump
- Inlet isolation valve on each pump
- Flexible connectors between pumps and receiver
- Flexible connectors for discharge connections

Vacuum Receiver

- Vertical orientation with integrally mounted bypass and manual drain
- ASME Code stamped
- National Board Certified
- Rated for a minimum 200 PSIG design pressure
- Vacuum gauge
- Manual drain

Control System

- Mounted and wired quad control system
- NEMA 12 and U.L. labeled
- Automatic lead/lag sequencing
- Circuit breaker disconnects for each motor with external operators
- Full voltage motor starters with overload protection
- 120V control circuit transformers for each motor circuit
- Visual and audible reserve unit alarm with isolated contacts for remote alarm
- Hand-off-auto selector switches
- Automatic alternation of all vacuum pumps based on a first-on/first-off principle with provisions for simultaneous operation if required
- Automatic activation of reserve unit if required
- Visual and audible alarm indication for high discharge temperature shutdown with isolated contacts for remote alarm
- SIGNAL 1™ – touch screen gateway

Standard Screen Displays

- | | |
|------------------------|--|
| + Air level/Runtime | + Replacement parts |
| + Alarm history | + Troubleshooting guidelines |
| + Service indicator | + Historical Trending of system status |
| + Maintenance schedule | |
- + 7" Wide TFT Graphic Touch Screen with Motion Actuated Backlit LED and Bright 65,536 (16-bit) Colors
 - + Downloadable Trend Information via USB Host Port or Network Device
 - + 128MB Flash Memory, 64MB DRAM
 - + Built-in Ethernet Port 10/100 Base-T (RJ45)
 - + Supports over 100 Communication Protocols including BACnet IP, Ethernet IP, and Modbus TCP/IP
 - + Built-in Multiple Ports it can handle three (3) additional Protocols simultaneously
 - + Built-in VNC server allowing remote monitoring over Ethernet/Internet network for "Real Time" monitoring of live graphics through standard browser, smart phones & mobile devices
 - + Share data between HMI and Building Management systems with no additional software to implement

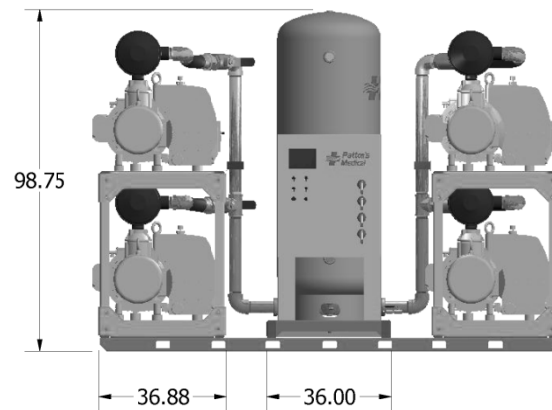
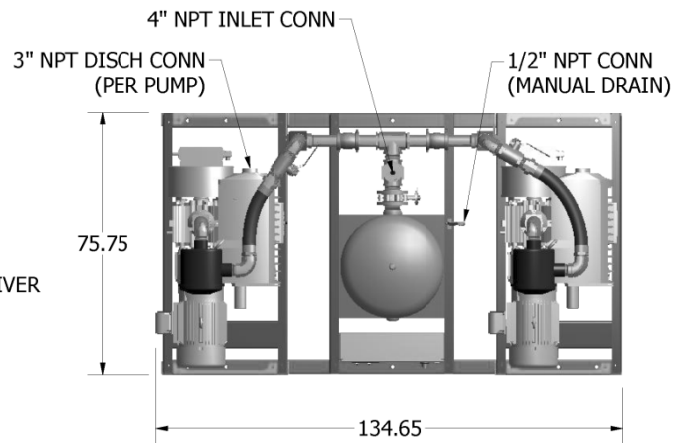
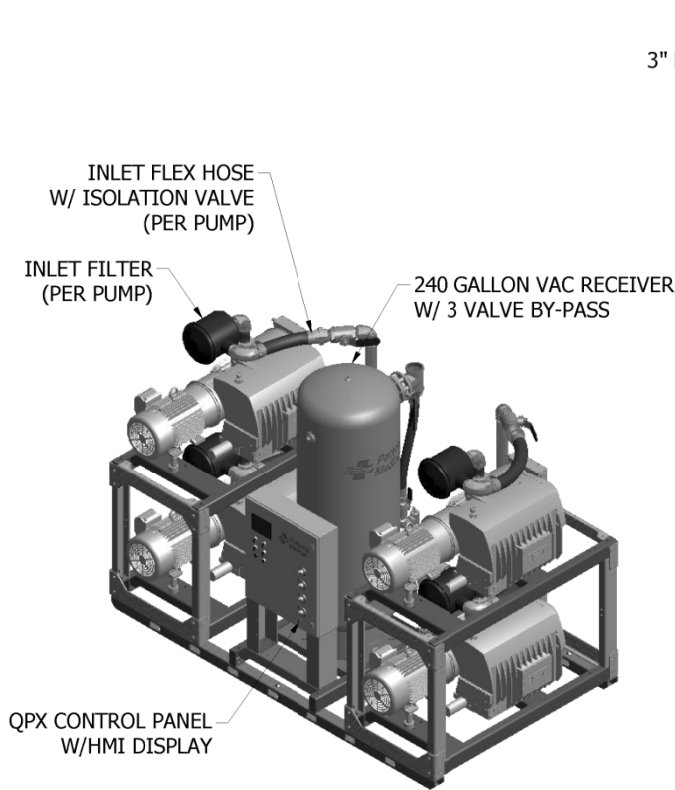

Quad Lubricated Rotary Vane Medical Vacuum Package Specifications ¹										
System Model No.	HP	Capacity @19" Hg ²		Package BTU/HR ³	Receiver Gal. ⁴	Noise Level ⁵	System FLA			Package Weight
		Pump (SCFM)	System (SCFM)				208V	230V	460V	
72-43-205A	20	137	411	153,000	240	90	219			8988
72-43-205B								203		
72-43-205C									102	

Notes:

¹ Normal Operating conditions at a maximum ambient of 105° F. Consult factory for higher ambient conditions.

² Capacities are shown as NFPA system capacities (reserve vacuum pump on standby).

³ Package BTU/HR are shown with the reserve pump on standby.

⁴ Receivers of 200 gallon capacity are standard

⁵ Noise levels are shown in dB(A) and reflect three pumps running.

Statement of Warranty

Patton's Medical warrants all Medical Vacuum packages, to be free of defects in material and workmanship under normal use for a period not to exceed thirty (30) months from date of shipment, or twenty-four (24) months from date of start-up.