

## NFPA 99 Compliant Quad Lubricated Rotary Vane Medical Vacuum Package 7.5 HP Base Mount with Single Point Connection

### Vacuum Package

- Fully compliant with the latest edition of NFPA 99
- Four lubricated rotary vane type vacuum pumps with inlet filter and isolation valve for each
- Four motors
- ASME coded vertical air receiver with bypass and manual drain
- Quad control panel with automatic lead/lag controls
- All components completely pre-piped and pre-wired to single point service connections
- Vibration isolation mountings
- Liquid tight conduit, fittings and junction boxes for all control and power wiring
- All interconnecting piping and wiring is completed and operationally tested prior to shipment

### Vacuum Pump

- Lubricated rotary vane pump
- Three non-metallic, non-asbestos vanes with minimum life of 30,000 hrs.
- Direct-driven through a shaft coupling
- Air-cooled
- End (ultimate) vacuum = 29.3" Hg
- Integral, fully recirculating oil supply
- Spin-on oil filter
- High discharge temperature switch
- Oil drain valve assembly with temperature gauge
- Uses SAE 30 weight oil
- Integral oil separation system with three stage oil and smoke eliminators capable of removing 99.9+% of particles from the exhaust gas stream
- Built-in, anti-suck-back valve mounted at the pump inlet
- Inlet filter for removal of particulates

### Vacuum Motor

- NEMA rated
- C-face
- TEFC
- 208 or 230/460V 3-phase

### Intake Piping

- Vacuum pumps are connected to a common manifold and piped to a vertical receiver
- Inlet check valve on each pump
- Inlet isolation valve on each pump
- Flexible connectors between pumps and receiver
- Flexible connectors for discharge connections

### Vacuum Receiver

- Vertical orientation with integrally mounted bypass and manual drain
- ASME Code stamped
- National Board Certified
- Rated for a minimum 200 PSIG design pressure
- Vacuum gauge
- Manual drain

### Control System

- Mounted and wired quad control system
- NEMA 12 and U.L. labeled
- Automatic lead/lag sequencing
- Circuit breaker disconnects for each motor with external operators
- Full voltage motor starters with overload protection
- 120V control circuit transformers for each motor circuit
- Visual and audible reserve unit alarm with isolated contacts for remote alarm
- Hand-off-auto selector switches
- Automatic alternation of all vacuum pumps based on a first-on/first-off principle with provisions for simultaneous operation if required
- Automatic activation of reserve unit if required
- Visual and audible alarm indication for high discharge temperature shutdown with isolated contacts for remote alarm
- SIGNAL 1™ – touch screen gateway

#### Standard Screen Displays

- |                        |  |
|------------------------|--|
| + Air level/Runtime    | + Replacement parts                    |
| + Alarm history        | + Troubleshooting guidelines           |
| + Service indicator    | + Historical Trending of system status |
| + Maintenance schedule |  |
- + 7" Wide TFT Graphic Touch Screen with Motion Actuated Backlit LED and Bright 65,536 (16-bit) Colors
  - + Downloadable Trend Information via USB Host Port or Network Device
  - + 128MB Flash Memory, 64MB DRAM
  - + Built-in Ethernet Port 10/100 Base-T (RJ45)
  - + Supports over 100 Communication Protocols including BACnet IP, Ethernet IP, and Modbus TCP/IP
  - + Built-in Multiple Ports it can handle three (3) additional Protocols simultaneously
  - + Built-in VNC server allowing remote monitoring over Ethernet/Internet network for "Real Time" monitoring of live graphics through standard browser, smart phones & mobile devices
  - + Share data between HMI and Building Management systems with no additional software to implement

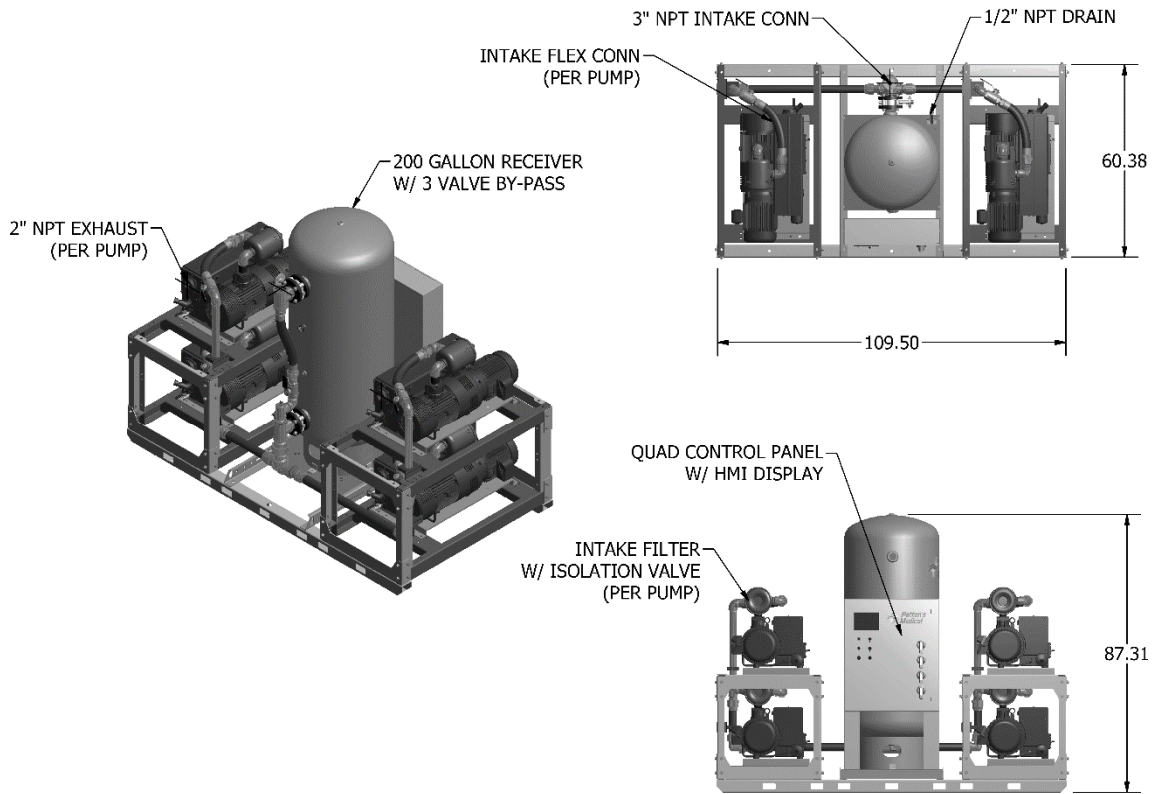

Quad Lubricated Rotary Vane Medical Vacuum Package Specifications <sup>1</sup>										
System Model No.	HP	Capacity @19" Hg <sup>2</sup>		Package BTU/HR <sup>3</sup>	Receiver Gal. <sup>4</sup>	Noise Level <sup>5</sup>	System FLA			Package Weight
		Pump (SCFM)	System (SCFM)				208V	230V	460V	
72-43-074A	7.5	52	156	50,933	200	85	86.8			3653
72-43-074B								84.0		
72-43-074C									42.0	

Notes:

- <sup>1</sup> Normal Operating conditions at a maximum ambient of 105° F. Consult factory for higher ambient conditions.
- <sup>2</sup> Capacities are shown as NFPA system capacities (reserve vacuum pump on standby).
- <sup>3</sup> Package BTU/HR are shown with the reserve pump on standby.
- <sup>4</sup> Receivers of 200 gallon capacity are standard
- <sup>5</sup> Noise levels are shown in dB(A) and reflect three pumps running.

**Statement of Warranty**

**Patton's Medical** warrants all Medical Vacuum packages, to be free of defects in material and workmanship under normal use for a period not to exceed thirty (30) months from date of shipment, or twenty-four (24) months from date of start-up.