

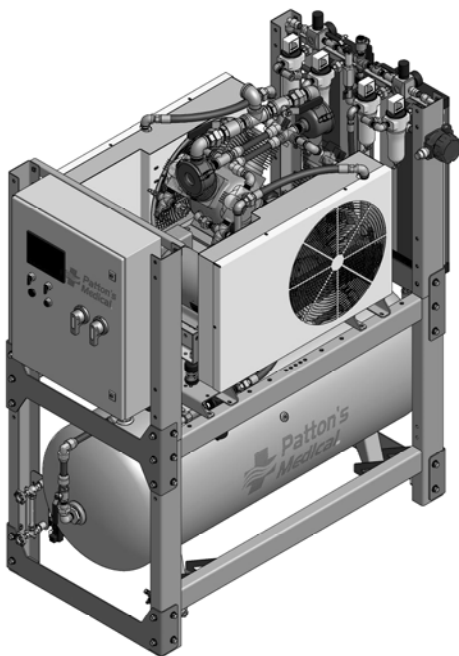

Reciprocating Medical Air System

SIGNAL 1

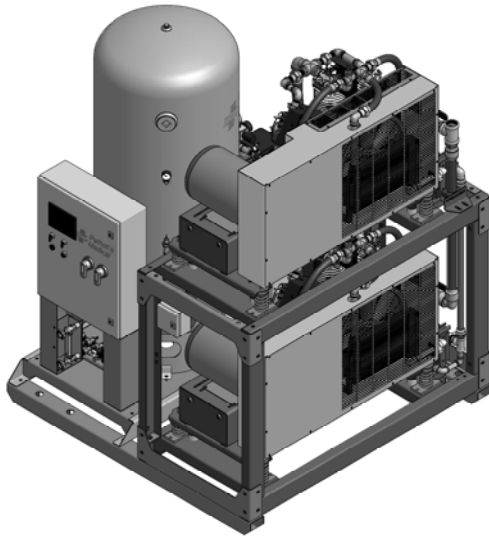

Installation Operation and Maintenance Manual 1 - 20 Hp



Oil-Less Reciprocating Medical Air System

Model Number:	
Serial Number:	
Date Purchased:	
Purchased from:	

For further technical assistance, service or replacement parts, please contact:

Patton's Medical

3201 South Boulevard
Charlotte, NC 28209

Customer Service: 1-866-960-0087

Phone: 704-529-5442

FAX: 704-525-5148

www.pattonsmmedical.com

Please include the unit serial number located on the control panel with all inquiries.

Patton's Medical reserves the right to make changes and improvements to update products sold previously without notice or obligation.

Issue Date: November 11, 2014

Table of Contents

Safety Precautions

1.0 General Information

2.0 Installation

- 2.1 Inspection Upon Receiving
- 2.2 Handling
- 2.3 Location
- 2.4 Space Requirements
- 2.5 Piping
- 2.6 Wiring

3.0 Control Panel

- 3.1 *Signal 1* System touch screen gateway
- 3.2 *Signal 1* Main Display Screen
- 3.3 Control Buttons
 - 3.3.1 “Menu”
 - 3.3.2 “Main”
 - 3.3.3 “Alarm History”
 - 3.3.4 “History”
 - 3.3.5 “Pressure Trend”
 - 3.3.6 “System Pressure History”
 - 3.3.7 “Dew Point Trend”
 - 3.3.8 “DP History”
 - 3.3.9 “CO Trend”
 - 3.3.10 “CO History”
 - 3.3.11 “Number Pumps Running Trend”
 - 3.3.12 “Pumps Running History”
 - 3.3.13 “System Data”
 - 3.3.14 “Parts Menu”
 - 3.3.15 “System Service & Pump Service”
 - 3.3.16 “Pressure Setting”
 - 3.3.17 “Trouble Shooting Guide”

4.0 System Operation

- 4.1 Prestart-up
- 4.2 Initial Start-up
- 4.3 Normal Start-up
- 4.4 Normal Operation
- 4.5 Normal Shutdown
- 4.6 Emergency Shutdown/Alarms

5.0 Trouble Shooting

6.0 Maintenance

- 6.1 Maintenance Schedule
- 6.2 Replacement Filter Elements

7.0 Inspection/Replacement Procedures

- 7.1 V-belts
 - 7.1.2 V-Belt Tension Adjustment
 - 7.1.3 Changing the V-Belts
- 7.2 Air Intake Filter
- 7.3 Readjustment of Back up Pressure Switch
- 7.4 CO Sensor
- 7.5 Dew Point Sensor
- 7.6 Desiccant Air Dryers
 - 7.6.1 Removing and replacing the front panel
 - 7.6.2 Purge plug removal for dryers 8-65 scfm
 - 7.6.3 Purge plug removal for dryers 85-365 scfm
 - 7.6.4 Cleaning the silencer for dryers 8-65 scfm
 - 7.6.5 Cleaning the silencer for dryers 85-365 scfm
 - 7.6.6 Replacing the diaphragm on dryers 8-65 scfm
 - 7.6.7 Replacing exhaust valve assembly and exhaust shuttles on dryers 85-365 scfm
 - 7.6.8 Changing the desiccant cartridges 8-65 CFM
 - 7.6.9 Changing the desiccant cartridges 85-365 CFM
 - 7.6.10 Dryer Service and fault diagnosis chart

8.0 Compressor Replacement Parts

- 8.1 G-Series parts 1 Hp
- 8.2 G-Series parts 2 Hp
- 8.3 G-Series parts 3 Hp
- 8.4 G-Series parts 5 Hp
- 8.5 G-Series parts 7.5 Hp
- 8.6 G-Series parts 10 Hp
- 8.7 G-Series parts 15 Hp
- 8.8 G-Series parts 20 Hp

9.0 Warranty

10.0 Maintenance Record

Safety Precautions

Pressurized air from the system may cause personnel injury or property damage if the unit is improperly operated or maintained. The operator should have carefully read and become familiar with the contents of this manual before installing, wiring, starting, operating, adjusting and maintaining the system. The operator is expected to use common sense safety precautions, good workmanship practices and follow any related local safety precautions.

In addition:

- **Before starting any installation or maintenance procedures, disconnect all power to the package.**
- All electrical procedures must be in compliance with all national, state and local codes and requirements.
- A certified electrician should connect all wiring.
- Refer to the electrical wiring diagram provided with the unit before starting any installation or maintenance work.
- Release all pressure from the package before removing, loosening, or servicing any covers, guards, fittings, connections, or other devices.
- Notify appropriate hospital personnel if repairs or maintenance will affect available compressed air levels.
- Air inlet must be placed in an area free of toxic or hazardous contaminants. It must be kept away from ETO exhaust vents, vacuum exhaust vents, areas close to automotive exhausts, etc., in accordance with the latest edition of NFPA 99.
- Prior to using the Medical Air System, the medical facility must have a certifier perform all installation tests as specified in the latest edition of NFPA 99 and is responsible for ensuring that the Medical Air meets the minimum requirements as specified in the latest edition of NFPA 99.
- This is a high speed, rotating piece of machinery. Do not attempt to service any part while machine is in operation.
- Do not operate unit without belt guards, shields or screens in place.
- Make sure that all loose articles, packing material, and tools are clear of the package.
- Check all safety devices periodically for proper operation.
- Never operate a compressor with its isolation (shutoff) valve closed or without its relief valve in place. Damage to the compressor may occur.
- **Do not add lubricating oil of any kind to the compressor.**
- The "Hand" mode of operation should only be used for emergencies such as a PLC malfunction and should not be used for normal operation.
- Electrical service must be the same as specified on the control panel nameplate or damage to the equipment may occur.
- Vibration during shipment can loosen electrical terminals, fuse inserts, and mechanical connections. Tighten as necessary.

1.0 General Information

System Configurations

The Reciprocating Medical Air systems are either base mounted or tank mounted units in configurations of duplex, triplex, quadruplex or other multiplexed configurations. All are compliant to the latest edition of the NFPA 99 code and consist of at least two compressors, two motors, two desiccant dryers with purge control, two pre-filters, two afterfilters and regulators, an integral pre-wired control panel and corrosion resistant air receiver. The systems are constructed as either single point connection (SPC) or modular packages. The complete package is pre-wired, pre-piped, and assembled either on one common base with single point connections for electrical, intake air, discharge air, and condensation drain or as a modular system with similar connection points.

Compressor Module

The compressor is a continuous duty rated "oil-less" reciprocating type with permanently lubricated, sealed bearings. The design is single stage and air cooled with corrosion resistant reed type valves with stainless steel reeds. Both the compression rings and rider rings are made from a long life, fluororesin material designed for continuous duty operation. The crankshaft is constructed of a durable nodular graphite cast iron and designed to be fully supported on both ends by heavy duty ball bearings permanently lubricated and sealed. The crankcase is constructed of gray cast iron, not aluminum. Maximum heat dissipation is achieved through cast aluminum alloy cylinders treated for optimum corrosion and wear resistance. Cylinder sleeves are not required. Additionally, heat transmission from the piston wall to the piston pin needle bearing is minimized by an insulated "heat cut" piston pin. The connecting rod is of a one piece design for maximum reliability.

Compressor Drive and Motor

The compressor is v-belt driven and protected by an OSHA approved totally enclosed belt guard. A slotted mounting base allows full adjustment for belt tensioning. The motor is a NEMA rated, open drip proof, with 1.15 service factor suitable for 208 or 230/460V electrical service.

Intake Piping

Each compressor has a piped intake with one "hospital type" inlet air filter and threaded opening for remote intake piping. The inlet filter removes dust from the incoming air through cyclonic action and through an element.

Discharge Piping

Each compressor (5–20HP) is equipped with an integral air-cooled aftercooler designed for a maximum approach temperature of 10° F complete with automatic solenoid drain valve. Each compressor is equipped with a wired high discharge air temperature shutdown switch. The compressor discharge line includes a flex connector, safety relief valve, isolation valve and check

1.0 General Information (continued)

valve. The discharge air piping is made of ASTM B-819 copper tubing, brass, aluminum, and/or stainless steel. The discharge flex connector is braided, 304 stainless steel, brass, or bronze.

Isolation System

The compressor and motor are fully isolated from the system base by means of a four-point, heavy duty, isolation system for a minimum of 95% isolation efficiency.

Dryer

Each desiccant dryer is individually sized for peak calculated demand and capable of producing a -40°F (-40°C) pressure dew point. Dryer purge flow is minimized through a demand-based purge saving control system. Isolation valves to permit servicing without shutting down the medical air system along with an air sample port are included.

Control System

The mounted and wired control system is NEMA 12 and U.L. labeled. The control system provides automatic lead/lag sequencing with circuit breaker disconnects for each motor with external operators. The control panel also includes full voltage motor starters with overload protection, redundant 120V control circuit transformers, visual and audible reserve unit alarm with isolated contacts for remote alarm, hand-off-auto selector switches, and runtime hourmeters. Automatic alternation of compressors is based on a first-on/first-off principle with provisions for simultaneous operation if required and automatic activation of the reserve unit if required. Visual and audible alarms indicators for high discharge air temperature shutdown, with isolated contacts for remote alarm, are included.

A **Signal 1 System touch screen gateway** is mounted in the control panel door. It includes:

- a pressure display
- a runtime display
- dew point/CO monitoring
- a dew point trend display
- a CO trend display
- a pressure trend display
- a trend display showing number of pumps running
- an alarm history display
- ability to download trending and history files to PC
- a maintenance schedule and history display
- a system service indicator
- a pump service indicator
- a replacement parts display
- a battery backup for history data
- a pressure set point adjustment display
- a system data display

1.0 General Information (continued)

Final Line Filters and Regulators

The inlet to each dryer includes a mounted high efficiency coalescing pre-filter rated for 0.01 micron mounted on each dryer with automatic solenoid drain and element change indicator. A particulate final line filter rated for 0.01 micron is mounted on each dryer with element change indicator along with a final line regulator and safety relief valve.

Dew Point Sensor/CO Sensor

The factory mounted, piped and wired, dew point sensor/CO sensor include remote alarm contacts. The dew point sensor is a ceramic type with system accuracy of $\pm 2^{\circ}$ F. The CO sensor is a chemical type with system accuracy of ± 2 PPM (at 10 PPM) for carbon monoxide. The dew point alarm is factory set at 36° F (2° C) per NFPA 99, and the CO alarm is factory set at 10 PPM. High CO and high dew point conditions are indicated with visual and audible alarms. The alarms are also logged to the “History” screen on the HMI.

Air Receiver

The vertical air receiver is corrosion resistant, ASME Coded, National Board Certified, and rated for a minimum 200 PSIG design pressure. The tank piping includes a liquid level gauge glass, safety relief valve, manual drain valve, and a timed automatic solenoid drain valve.

2.0 Installation

2.1 Inspection upon Receiving

The Reciprocating Medical Air system should be carefully inspected upon delivery. Any damage by the carrier should be noted on the delivery receipt, especially if the system will not be immediately uncrated and installed. The system may remain in its shipping container(s) until ready for installation. If the system is to be stored prior to installation, it must be protected from the elements to prevent rust and deterioration.

DO NOT REMOVE the protective covers from the inlet and discharge connection ports of the unit until they are ready for connecting to the hospital's pipeline distribution system.

2.2 Handling

!!WARNING!!

USE APPROPRIATE LOAD RATED LIFTING EQUIPMENT AND OBSERVE SAFE LIFTING PROCEDURES DURING ALL MOVES.

The compressor package can be moved with either a forklift or dollies. Be sure that the orange spacers used to prevent the compressor/motor base from unnecessary movement while moving and/or mounting the unit are in place. Keep all packing in place during installation to minimize damage. Examine the route the unit must travel and note dimensions of doorways and low ceilings. The 2-5 hp systems are designed to go through 36" doorways. The 7-1/2 hp-20 hp systems, must be separated to go through 36" doorways. If this is necessary, carefully label all electrical connections that are removed for easier re-assembling at the final destination. Units should be placed to ensure easy access to perform maintenance and high visibility of indicators and gauges.

2.3 Location

The Medical Air system should be installed indoors in a clean, well-ventilated environment. Areas of excessive dust, dirt or other air-borne particulate should be avoided.

Secure the package to a flat, level surface capable of supporting the weight and forces of the unit. Make sure that the main base is not bowed, twisted, or uneven. Because of the internal flexible hose connections and spring isolators, **no special foundation is required**. However, the unit base must be securely bolted using all mounting holes provided in the base. If a raised concrete pad is used, the base must not overhang the concrete pad. A method to drain away moisture is necessary. If a gravity drain is not available, a connection to a drain is necessary. After securing the unit to the floor, remove the orange spacers from under the compressor/motor base.

2.0 Installation (continued)

2.3 Location (continued)

The area should have an average ambient temperature of 70°F (21°C) with a minimum ambient temperature of 40°F (4.4°C) and a maximum ambient temperature of 104°F (40°C). **(Note: At temperatures below 32°F the bare compressor will not be adversely affected, but freezing of the condensate can occur which could affect operation.)**

Sound levels of 76 to 85 dbA are to be anticipated depending on the size of the package (duplex, triplex, quad). Though the sound levels are not excessive, they should be considered when locating the system.

2.4 Space Requirements

The Medical Air system should be placed to ensure easy access to perform maintenance and high visibility of indicators and gauges. It is recommended that a minimum space of 24" be allowed on all sides of the compressor system for ventilation and maintenance. A minimum space of 36" in front of the control panel is required by NEC code. A vertical distance of 36" is required above the unit for ventilation and maintenance.

2.5 Piping

2.5.1 Intake Piping

WARNING:

The air intake must be placed in an area free of toxic or hazardous contaminants; it must be kept away from ETO gas exhaust vents, vacuum exhaust vents, areas close to automotive exhausts, etc., in accordance with NFPA 99.

The air intake line must be piped to the outside in accordance with NFPA 99. To ensure that airflow restriction will not occur, size the piping according to the following chart. All piping must be pre-cleaned for medical gas in accordance with NFPA 99. The outside pipe must be turned down and screened to prevent contamination. The source of air is typically from outside the building. In hot humid areas, using the building's air-conditioned supply (per NFPA 99) may improve operating conditions of the system.

All of the 7.5-20 hp Single Point Connection (SPC) systems have the necessary flex connectors for the air intake and discharge factory piped, and no further flex connectors are needed. However, for the 1-5hp systems, the customer must install one intake flex connector.



Oil-Less Reciprocating Medical Air System

2.0 Installation (continued)

2.5 Piping (continued)

2.5.1 Intake Piping (continued)

Medical Air Systems	System Pipe Length (ft) - See Notes											
	25	50	75	100	150	200	250	300	350	400	450	500
Duplex 1 HP	1.25	1.25	1.25	1.25	1.50	1.25	1.25	1.25	1.25	1.50	1.50	1.50
Duplex 2 HP	1.25	1.25	1.25	1.25	1.50	1.50	1.50	2.00	2.00	2.00	2.00	2.00
Duplex 3 HP	1.25	1.25	1.50	1.50	2.00	2.00	2.00	2.00	2.00	2.00	2.00	2.50
Duplex 5 HP	1.50	2.00	2.00	2.00	2.00	2.50	2.50	2.50	2.50	2.50	2.50	3.00
Duplex 7.5 HP	2.00	2.00	2.00	2.50	2.50	2.50	3.00	3.00	3.00	3.00	3.00	3.00
Duplex 10 HP	2.00	2.50	2.50	2.50	2.50	3.00	3.00	3.00	3.00	3.50	3.50	3.50
Duplex 15 HP	2.50	2.50	2.50	3.00	3.00	3.50	3.50	3.50	3.50	4.00	4.00	4.00
Duplex 20 HP	2.50	3.00	3.50	3.50	3.50	4.00	4.00	4.00	5.00	5.00	5.00	5.00
Triplex 7.5 HP	3.00	3.00	3.00	3.00	3.00	3.00	3.50	3.50	3.50	3.50	3.50	3.50
Triplex 10 HP	3.00	3.00	3.00	3.00	3.00	3.00	3.50	3.50	3.50	3.50	4.00	4.00
Triplex 15 HP	3.00	3.00	3.00	3.00	3.50	3.50	4.00	4.00	4.00	4.00	5.00	5.00
Triplex 20 HP	3.00	3.50	3.50	4.00	4.00	5.00	5.00	5.00	5.00	5.00	6.00	6.00
Quad 7.5 HP	3.00	3.00	3.00	3.00	3.00	3.50	3.50	3.50	4.00	4.00	4.00	4.00
Quad 10 HP	3.00	3.00	3.00	3.00	3.50	3.50	3.50	4.00	4.00	4.00	4.00	5.00
Quad 15 HP	3.00	3.00	3.50	3.50	4.00	4.00	5.00	5.00	5.00	5.00	5.00	5.00
Quad 20 HP	3.50	4.00	4.00	5.00	5.00	5.00	6.00	6.00	6.00	6.00	6.00	6.00
Pentaplex 15 HP	3.50	4.00	4.00	5.00	5.00	5.00	6.00	6.00	6.00	6.00	6.00	6.00
Pentaplex 20 HP	5.00	5.00	5.00	5.00	6.00	6.00	6.00	6.00	6.00	8.00	8.00	8.00
Hexaplex 15 HP	4.00	5.00	5.00	5.00	5.00	6.00	6.00	6.00	6.00	8.00	8.00	8.00
Hexaplex 20 HP	5.00	5.00	5.00	6.00	6.00	6.00	8.00	8.00	8.00	8.00	8.00	8.00

- 1) All pipe sizes are based on the following: copper pipe (Type L), 14.7 psia, 70 deg F.
- 2) The minimum pipe size must be maintained for the total length of the inlet pipe. Use next larger size pipe in the event the minimum size is not available.
- 3) When determining the total pipe length, add all the straight lengths of pipe together in addition to the number of elbows times the effective pipe length for that pipe size (See the table below.)

Effective Pipe length for each 90 deg elbow										
Pipe size (in.)	1.25	1.5	2.00	2.5	3	3.5	4	5	6	
Eff. Pipe Length (ft)	3.4	4	4.9	6.4	7.9	9.4	10.0	11.9	13.2	

2.0 Installation (continued)

2.5 Piping (continued)

2.5.2 Discharge Piping

A larger piping size may be required depending on the length of the distribution piping in the facility.

Systems	Pipe Size
Duplex 1 HP	1/2
Duplex 2 HP	1/2
Duplex 3 HP	1/2
Duplex 5 HP	3/4
Duplex 7.5 HP	3/4
Duplex 10 HP	3/4
Duplex 15 HP	1
Duplex 20 HP	1
Triplex 7.5 HP	1
Triplex 10 HP	1
Triplex 15 HP	1-1/4
Triplex 20 HP	1-1/4
Quad 7.5 HP	1
Quad 10 HP	1
Quad 15 HP	1-1/4
Quad 20 HP	1-1/2
Pentaplex 15 HP	1-1/2
Pentaplex 20 HP	1-1/2
Hexaplex 15 HP	1-1/2
Hexaplex 20 HP	1-1/2

2.0 Installation (continued)

2.6 Wiring

WARNING!

BE SURE TO DISCONNECT ALL ELECTRICAL POWER TO THE COMPRESSOR SYSTEM BEFORE PERFORMING ANY ELECTRICAL PROCEDURES.

Refer to the electrical diagram provided with the unit before starting any installation or maintenance work.

Do not operate compressor on a voltage other than the voltage specified on the compressor nameplate.

All customer wiring should be in compliance with the National Electrical Code and any other applicable state or local codes.

CAUTION: In the Duplex configuration, all voltages will be disconnected from the compressor modules using the circuit breaker. Opening the appropriate fused knife-switch disconnect, disconnects control power. Turning off the appropriate motor circuit breaker disconnects motor power.

Refer to the wiring diagram that came with the compressor system for pertinent wiring connections.

Electrical power for the Medical Air system must be supplied from the emergency life support circuit.

Check the control voltage, phase, and amp ratings before starting the electrical installation, and make sure the voltage supplied by the hospital is the same.

The wire size should be able to handle peak motor amp load of all operating units, refer to the full load and compressor system amperes on the wiring diagram.

Check all electrical connections within the air system that may have loosened during shipment.

Only qualified electricians should make power connections to the control panel and any inter-connecting wiring.

Ensure that the emergency generator system's electrical supply is consistent with the air system's requirements.

Three-phase power supplied from the emergency generator(s) must match that of the normal supply to allow for correct direction of the motor rotation at all times.

3.0 Control Panel



Duplex Control Panel

1. **Display Screen** – Displays the systems operating screens.
2. **LED's** – Yellow PWR: Power is correctly supplied
Green CPU: Indicates the Signal 1 is operating correctly
Red COM: Indicates communication with PLC
Not lighted: Power is not supplied
3. **HOA selector switch** – Compressor control switch, Hand – Off – Auto.
4. **Alarm horn** – Sounds when an alarm condition occurs.
5. **Alarm Reset/Horn Silence** – Pushbutton to silence alarm and reset visual alarm on *Signal 1* screen after alarm condition is corrected.
6. **Dryer Control Selector Switch** – Manual Purge - Off - Demand Purge
7. **External Operator** – To control circuit breaker disconnect

3.0 Control Panel (continued)

3.1 Signal 1 System touch screen gateway

The Reciprocating Medical Air system has a touch screen gateway to control and monitor the complete system operation as well as record service and alarm history of the unit and change pressure setting levels.

3.2 Signal 1 Main Display Screen The main screen for systems will monitor and display the system's dew point and CO readings, air receiver pressure, run sequence, individual unit total run hours and run status (HOA switch position). Included on this screen is a service due alarm, transducer fault alarms and lag alarm for the system as well as individual alarms for each compressor unit (motor overload, and high discharge air temperature). The "MENU" button in the upper right corner will allow the operator to navigate through the screens to view the system alarm history, service schedule and records, dew point, CO and pressure trends, basic troubleshooting, pressure settings, and system general information. When the **Signal 1** is powered up the main control window will appear on the display screen. This screen displays the systems current dew point, CO, pressure, total hours run for each module, run sequence, HOA switch setting and status of service schedule and alarm conditions.



3.0 Control Panel (continued)

3.2 Signal 1 Main Display Screen (Continued)

1. MENU: Displays menu screen which allows the operator to access the systems operating history, service requirements, dew point, CO, and pressure trends, troubleshooting info, pressure setting, and main system info.
2. DEW POINT (D/P): Display's the current dew point reading at the units discharge point. If the dew point reading is higher than 2°C, a high dew point alarm will occur. The dew point indicator will flash red and the horn will sound. Pressing the reset button on the face of the control panel will silence the alarm. Selecting the indicator when flashing red will open a troubleshooting window. The dew point indicator will continue to flash red until the dew point falls below 2°C. At this point the dew point alarm will reset.
3. CO: Display's the current CO reading at the units discharge point. If the CO reading is higher than 10 ppm, a high CO alarm will occur. The CO indicator will flash red and the horn will sound. Pressing the reset button on the face of the control panel will silence the alarm. Selecting the indicator when flashing red will open a troubleshooting window. The CO indicator will continue to flash red until the CO falls below 10 ppm. At this point the CO alarm will reset.
4. PRESSURE (PSI): Display's the current pressure inside the air receiver.
5. SERVICE DUE: Service intervals and types of service are preprogrammed into the *Signal 1*. The button will flash yellow when service is due. Pressing the "service due" button when flashing will display the system service schedule screen. If system service is required the item requiring service will be flashing red. If any of the pumps require service the correct pump number button will flash red, pressing that button will open the correct pump service screen
6. PRESSURE TDC FAULT: Indicator will flash red and horn will sound if the transducer fails. Pressure reading on the display screen will default to "-37" psi. Selecting the indicator when flashing red will open a trouble shooting window.
7. DEW POINT SENSOR FAULT: Indicator will flash red and horn will sound if the transducer fails. Dew point reading on the display screen will default to "-157". Selecting the indicator when flashing red will open a trouble shooting window.
8. CO SENSOR FAULT: Indicator will flash red and horn will sound if the transducer fails. CO reading on the display screen will default to "-74". Selecting the indicator when flashing red will open a trouble shooting window.
9. LAG ALARM: Indicator will flash red and horn will sound when last available compressor unit comes on. Press the reset button to silence the alarm. If the condition is corrected both the alarm and indicator will turn off. If a lag condition remains the indicating light on the *Signal 1* will remain on. Selecting the indicator when flashing red will open a trouble shooting window. Once the lag condition is corrected, press the reset button again to turn off the indicator.
10. UNIT RUN HOURS: Displays total run hours for each compressor module.
11. HAND-OFF-AUTO: Displays status of each compressor module. The green "HAND" displays when the compressor is running and the HOA selector switch is in the HAND setting.

3.0 Control Panel (continued)

3.2 HMI Main Display Screen (continued)

The green “AUTO” displays when the compressor is not running and the HOA selector switch is in the AUTO position. The “OFF” indicator is displayed when the HOA selector switch is in the “OFF” position.

12. **MOTOR OVLD:** Display will flash red and sound an alarm when overload switch is tripped in the control panel. The compressor in question will not re-start until the reset button on the starter inside the main control cabinet is reset (See “Motor overheating” in the Troubleshooting Section). Press the reset button on front panel to silence the alarm. Selecting the indicator when flashing red will open a trouble shooting window. The indicator on the *Signal 1* will remain on until motor starter is reset.
13. **HIGH TEMP:** Display will flash red and sound an alarm when the compressor unit is shut down due to high discharge air temperatures. Press the reset button on the front panel to clear the alarm. If the indicator light stays “ON”, the high temp condition still exists. Selecting the indicator when flashing red will open a trouble shooting window. The unit may not restart after pressing the reset button, depending on the system sequencing and system pressure.

3.0 Control Panel (continued)

3.3 Control Buttons

3.3.1 MENU

The MENU button in the upper right corner on the main screen when selected will display the “MENU” window that will allow the operator to access information shown on screen below. Each button will be explained in detail in this section.

3.3.2 – “MAIN” Button

The main button can be found on many of the screens within the *Signal 1* Controller. At any time when the “MAIN” button is selected, the *Signal 1* display will return to the Main Display Screen.

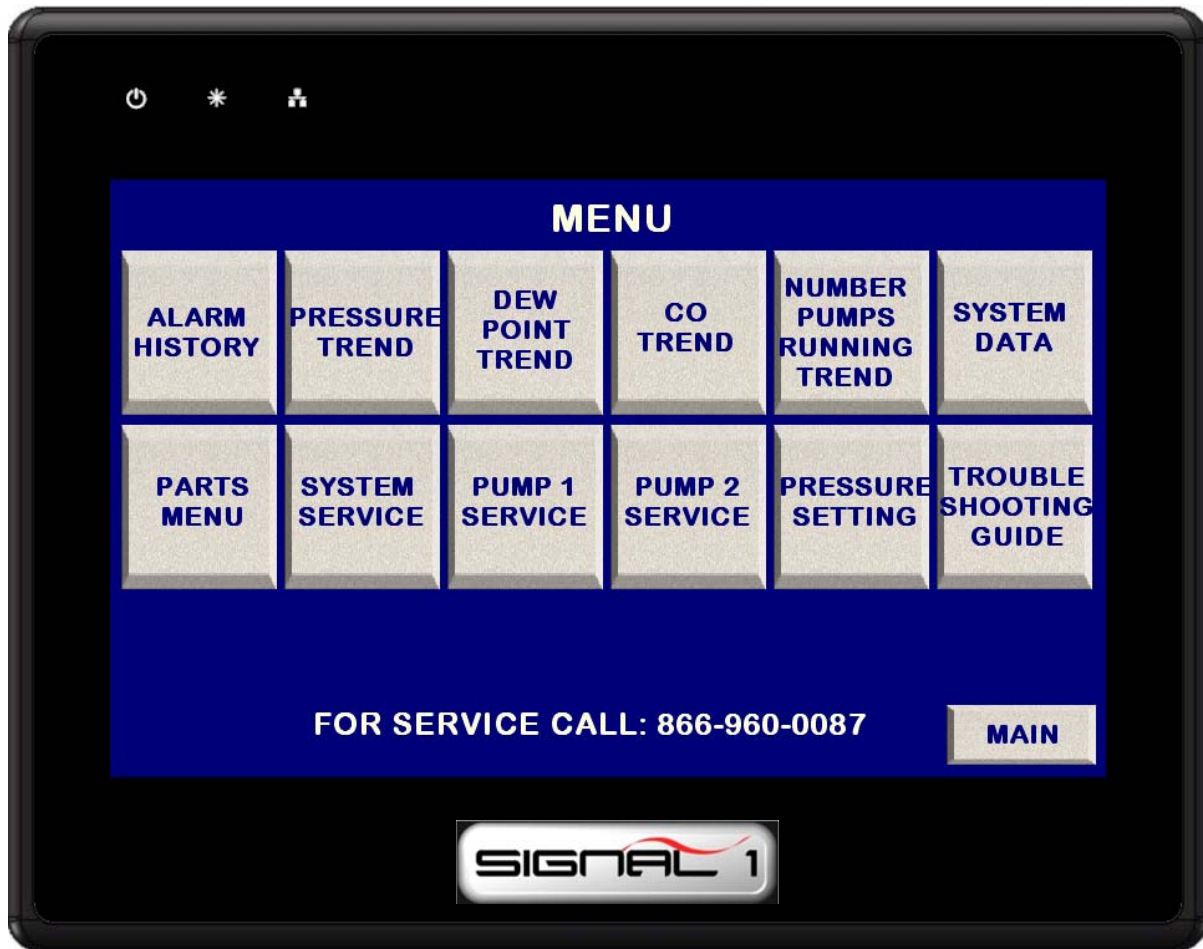

3.0 Control Panel (continued)

3.3 Control Buttons (continued)

3.3.3 – “ALARM HISTORY” Button

The “ALARM HISTORY” button on the “Menu” screen will open a new window listing all the alarm conditions that have occurred as well as routine maintenance alerts. The list will show the date and time of the incident, type of incident and when the condition was cleared/corrected. This creates a permanent record of the history of the unit and cannot be reset.

1. “MAIN” button will return you to the main screen.
2. “HISTORY” button will open a new History screen shown on the next page.

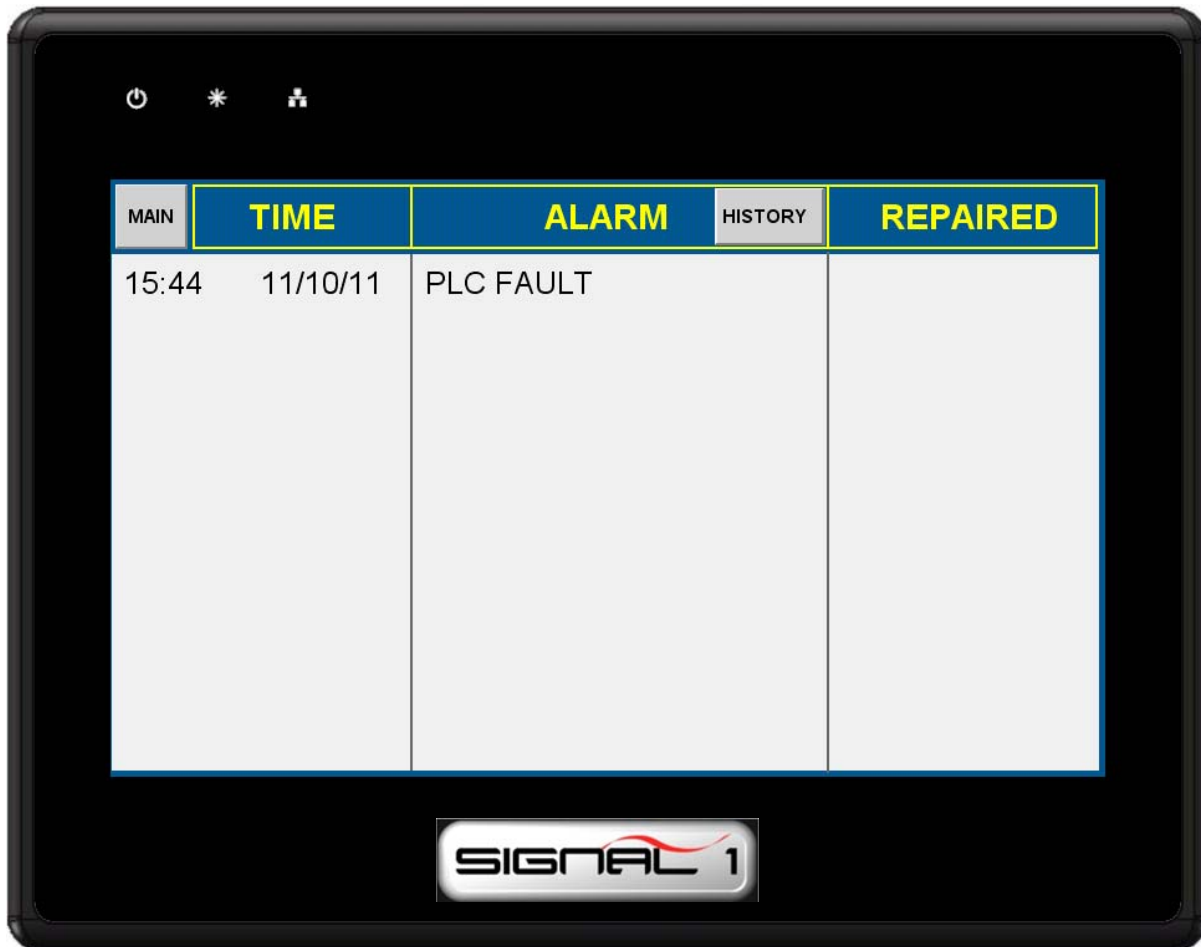

3.0 Control Panel (Continued)

3.3 Control Buttons (Continued)

3.3.4 – “**HISTORY**” screen displayed from pressing “History” button on “Alarm History” screen shown below. Pressing the up and down arrows will display alarm/maintenance history one day at a time. History can be down loaded to a USB memory stick by inserting the memory stick into the USB slot on the back of the *Signal 1* and pressing the “Download To USB” button on the screen. Files can be saved to PC and viewed in an excel format.

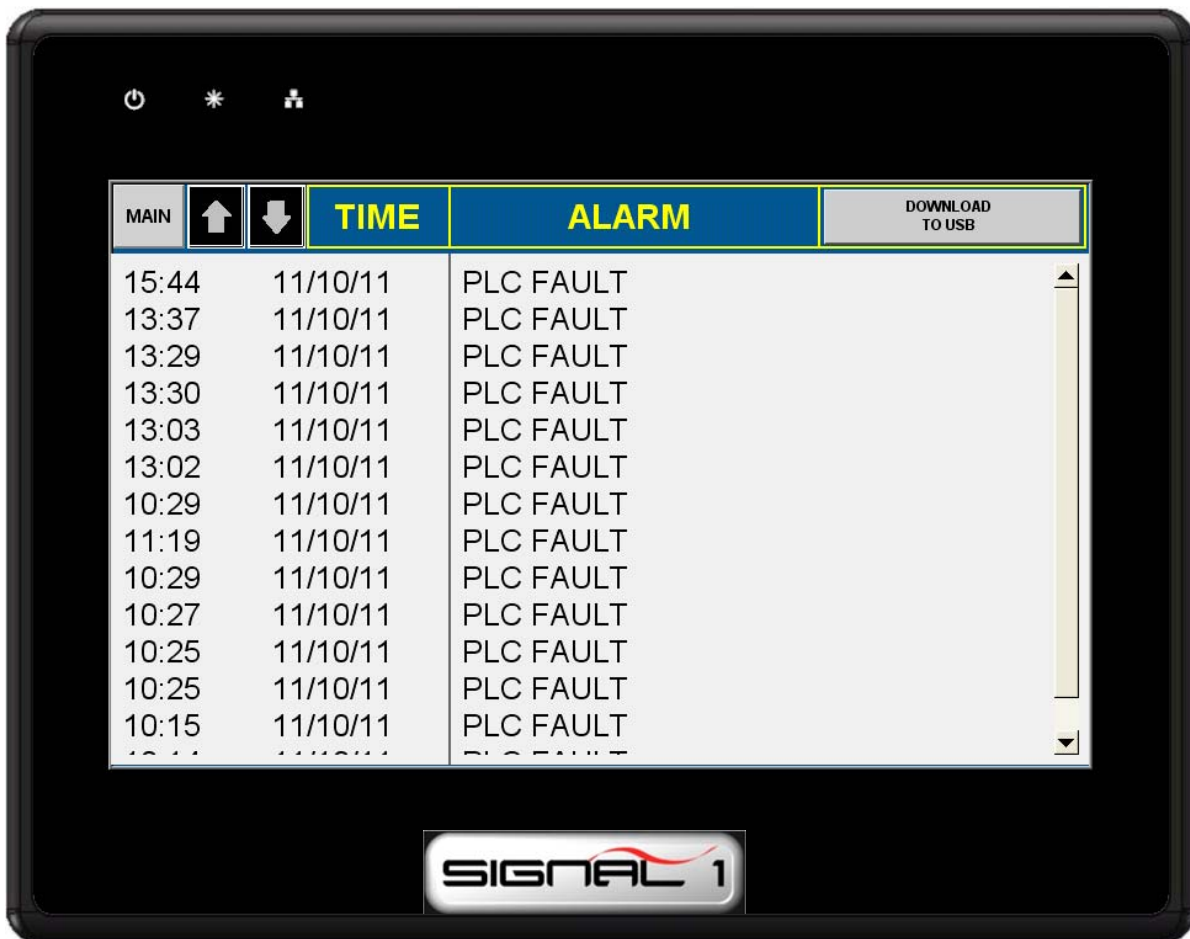

3.0 Control Panel (Continued)

3.3 Control Buttons (Continued)

3.3.5 – “PRESSURE TREND” Pressing the “Pressure Trend” button on the “Menu” screen will display the screen below. Screen displays 15 minutes of trending and has a scroll bar on the bottom of screen to scroll to different time frames.

1. “MAIN” button will return you to the main screen.
2. “SYSTEM PRESSURE HISTORY” button will open a new screen shown on the next page

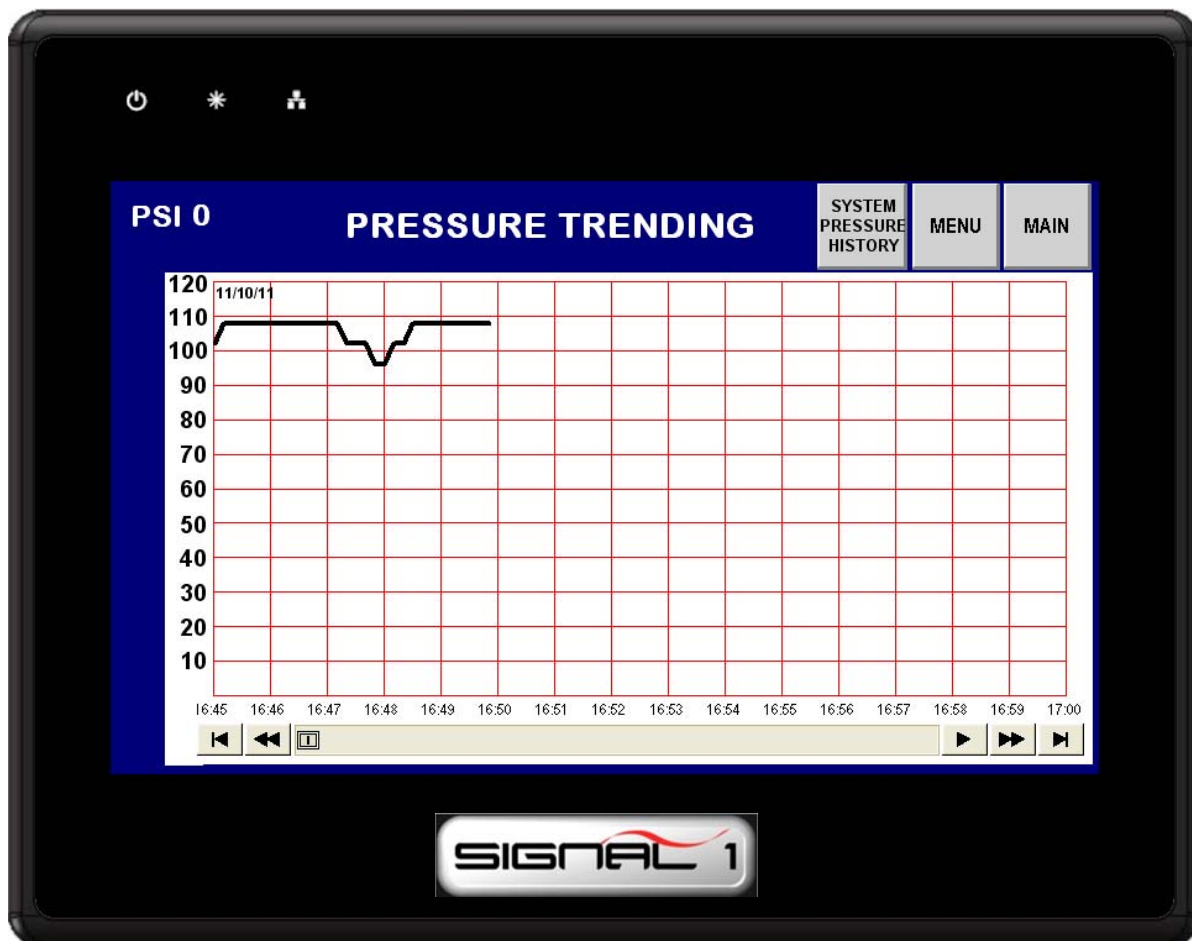

3.0 Control Panel (continued)

3.3 Control Buttons (continued)

3.3.6 – “SYSTEM PRESSURE HISTORY” screen shown below. Pressing the up and down arrows will display pressure trending history one day at a time. History can be down loaded to a USB memory stick by inserting the memory stick into the USB slot on the back of the *Signal 1* and pressing the “Download To USB” button on the screen. Files can be saved to PC and viewed in an excel format.

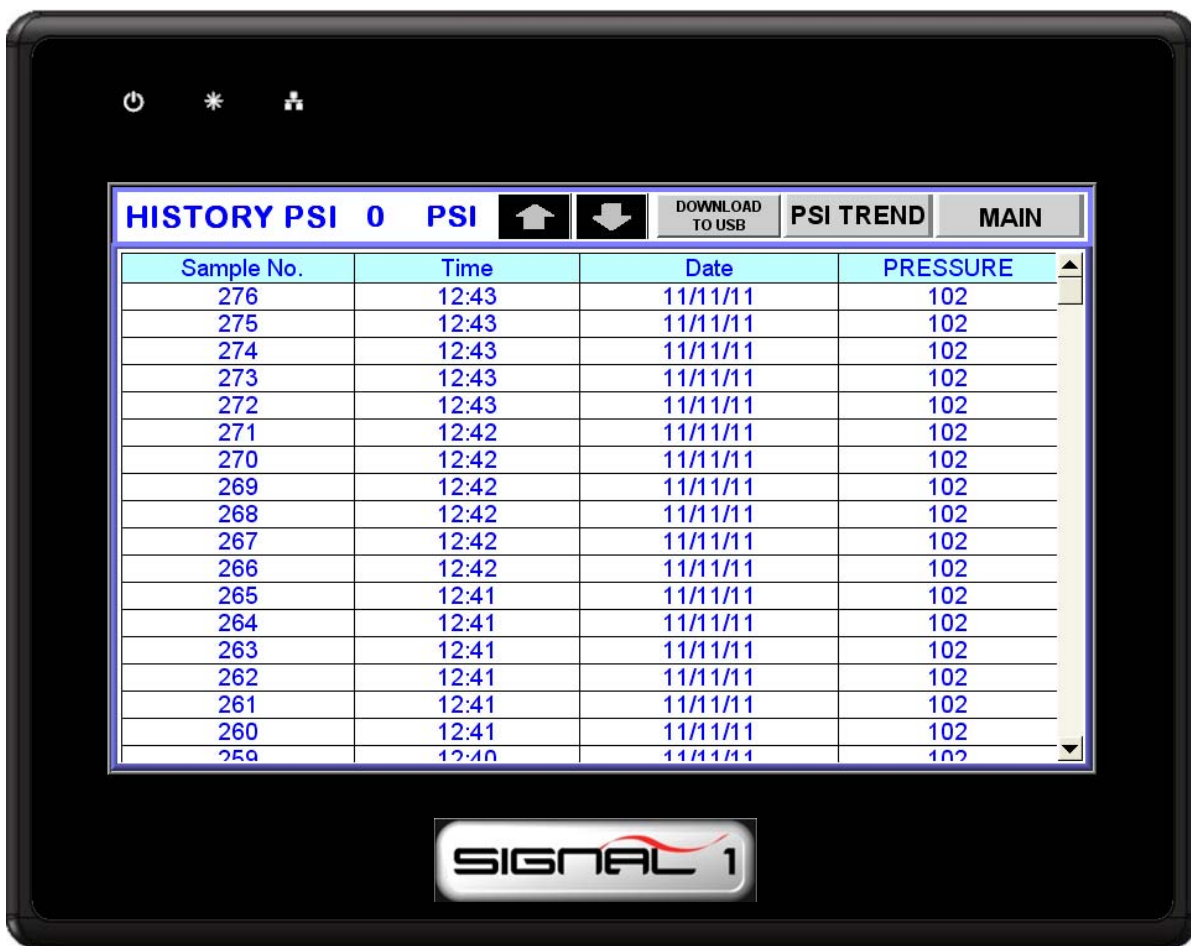

3.0 Control Panel (Continued)

3.3 Control Buttons (Continued)

3.3.7 – “DEW POINT TREND” Pressing the “Dew Point Trend” button on the “Menu” screen will display the screen below. Screen displays 15 minutes of trending and has a scroll bar on the bottom of screen to scroll to different time frames.

1. “MAIN” button will return you to the main screen.
2. “DP HISTORY” button will open a new screen shown on the next page.

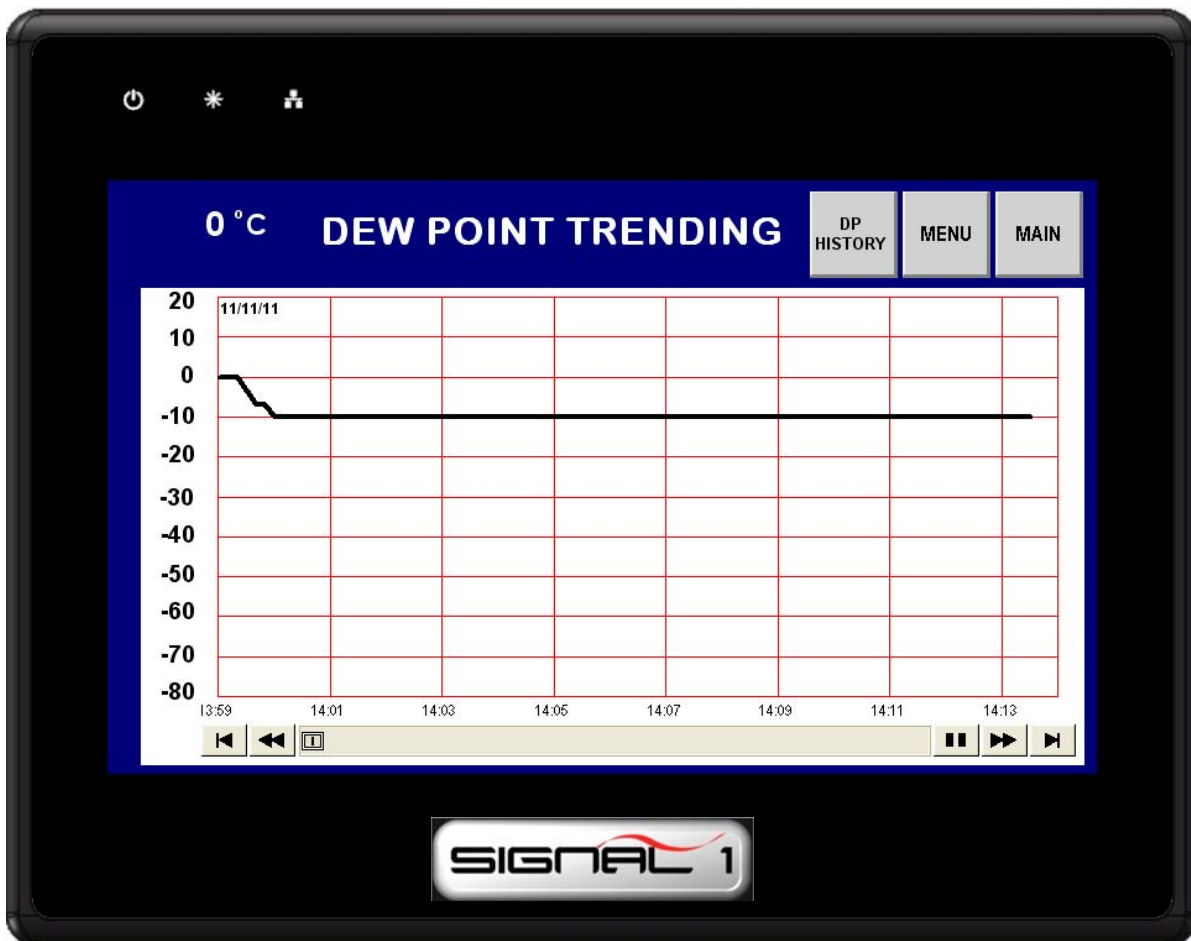

3.0 Control Panel (Continued)

3.3 Control Buttons (Continued)

3.3.8 – “DP HISTORY” screen shown below. Pressing the up and down arrows will display dew point trending history one day at a time. History can be down loaded to a USB memory stick by inserting the memory stick into the USB slot on the back of the *Signal 1* and pressing the “Download To USB” button on the screen. Files can be saved to PC and viewed in an excel format.

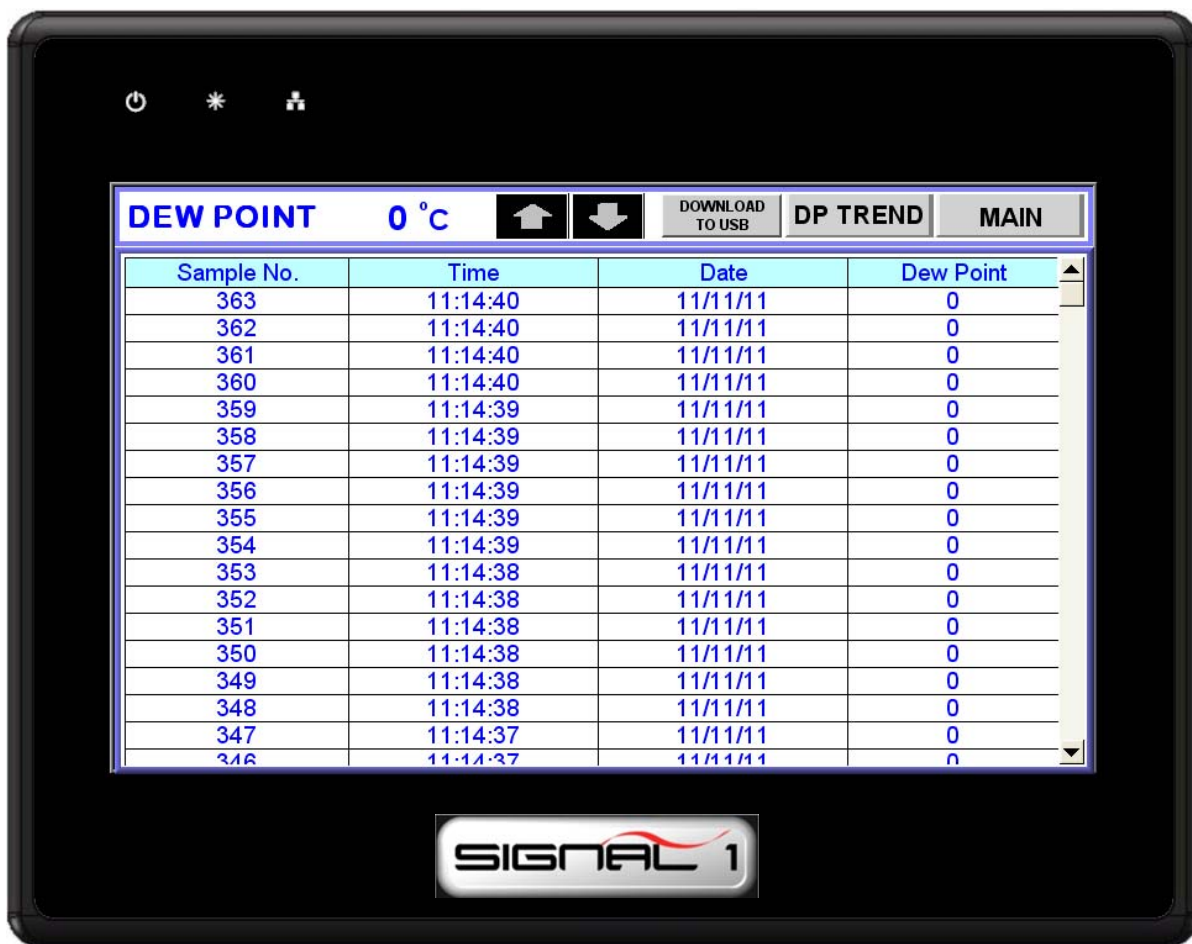

3.0 Control Panel (Continued)

3.3 Control Buttons

3.3.9 – “CO TREND” Pressing the “CO Trend” button on the “Menu” screen will display the screen below. Screen displays 15 minutes of trending and has a scroll bar on the bottom of screen to scroll to different time frames.

1. “MAIN” button will return you to the main screen.
2. “CO HISTORY” button will open a new screen shown on the next page.

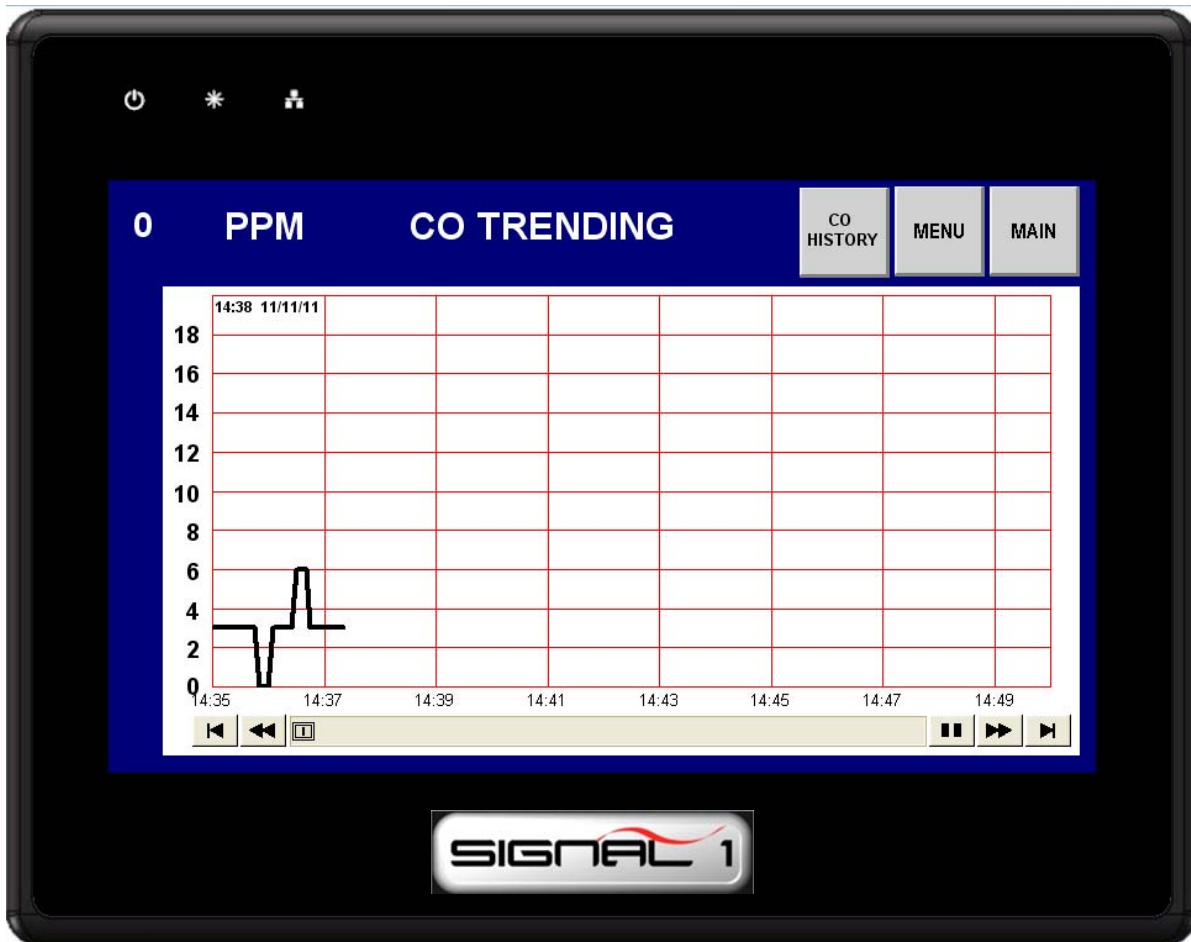

3.0 Control Panel (Continued)

3.3 Control Buttons

3.3.10 – “CO HISTORY” screen shown below. Pressing the up and down arrows will display CO trending history one day at a time. History can be down loaded to a USB memory stick by inserting the memory stick into the USB slot on the back of the *Signal 1* and pressing the “Download To USB” button on the screen. Files can be saved to PC and viewed in an excel format.



3.0 Control Panel (Continued)

3.3 Control Buttons

3.3.11 – “NUMBER PUMPS RUNNING TREND” Pressing the “NUMBER PUMPS RUNNING TREND” button on the “Menu” screen will display the screen below. Screen displays 15 minutes of trending and has a scroll bar on the bottom of screen to scroll to different time frames.

1. “MAIN” button will return you to the main screen.
2. “PUMPS RUNNING HISTORY” button will open a new screen shown on the next page

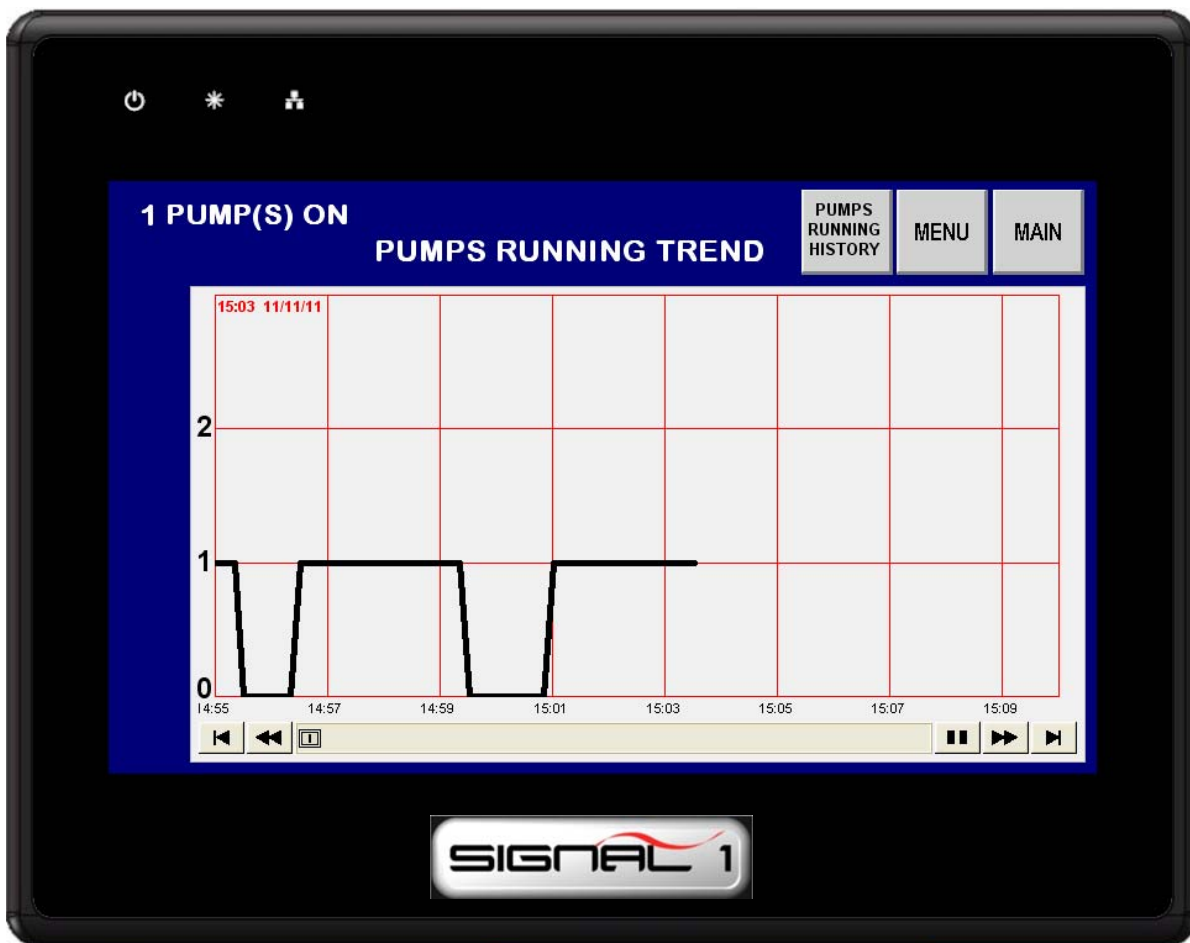

3.0 Control Panel (Continued)

3.3 Control Buttons

3.3.12 – “PUMPS RUNNING HISTORY” screen shown below. Pressing the up and down arrows will display number of pumps running trending history one day at a time. History can be down loaded to a USB memory stick by inserting the memory stick into the USB slot on the back of the *Signal 1* and pressing the “Download To USB” button on the screen. Files can be saved to PC and viewed in an excel format.

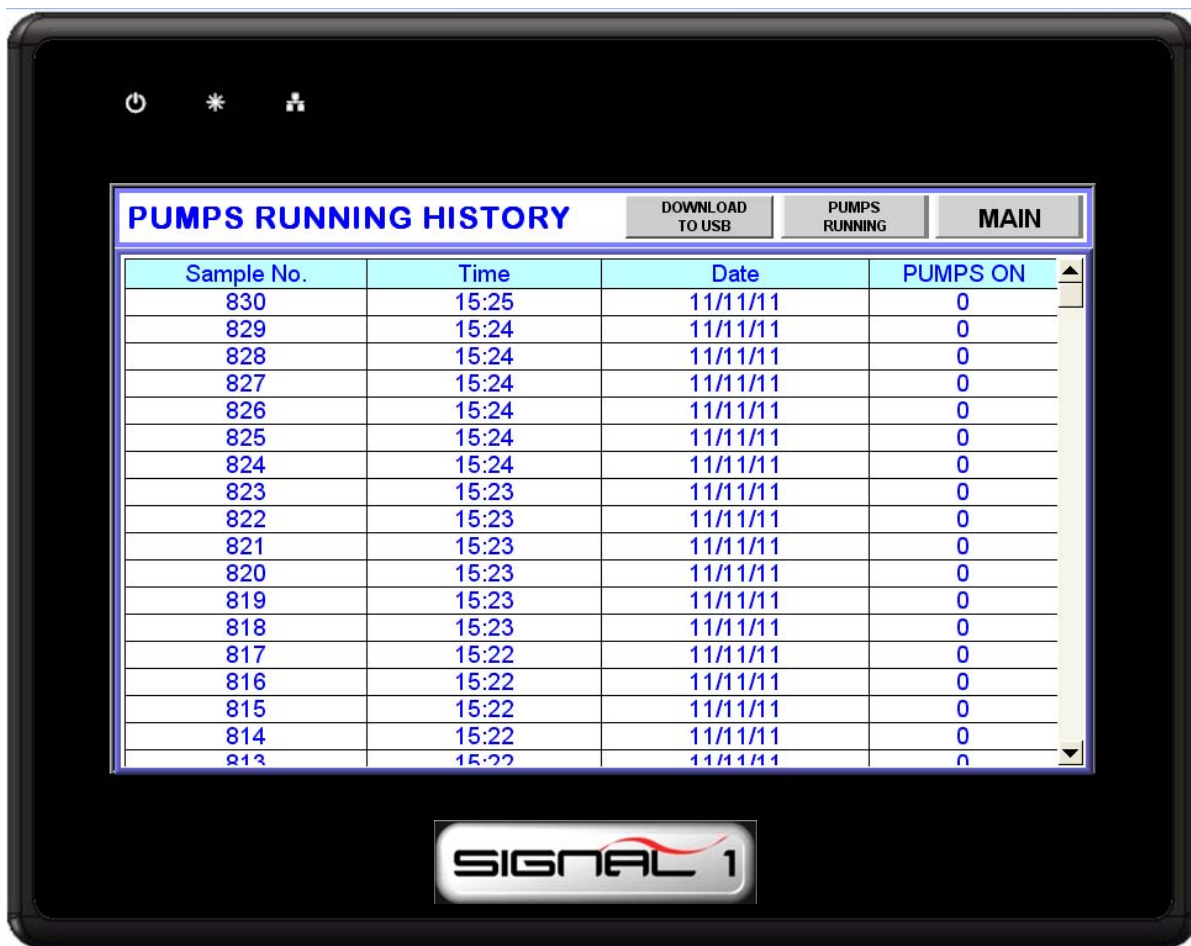

3.0 Control Panel (Continued)

3.3 Control Buttons

3.3.13 “SYSTEM DATA” Button

The “System Data” button displays all the system information required when scheduling maintenance or purchasing spare parts from Patton’s Medical. The information includes model number, serial number, horsepower, system voltage, and unit start up date. This information will be programmed into the *Signal 1* at startup by a Patton’s Medical authorized technician.

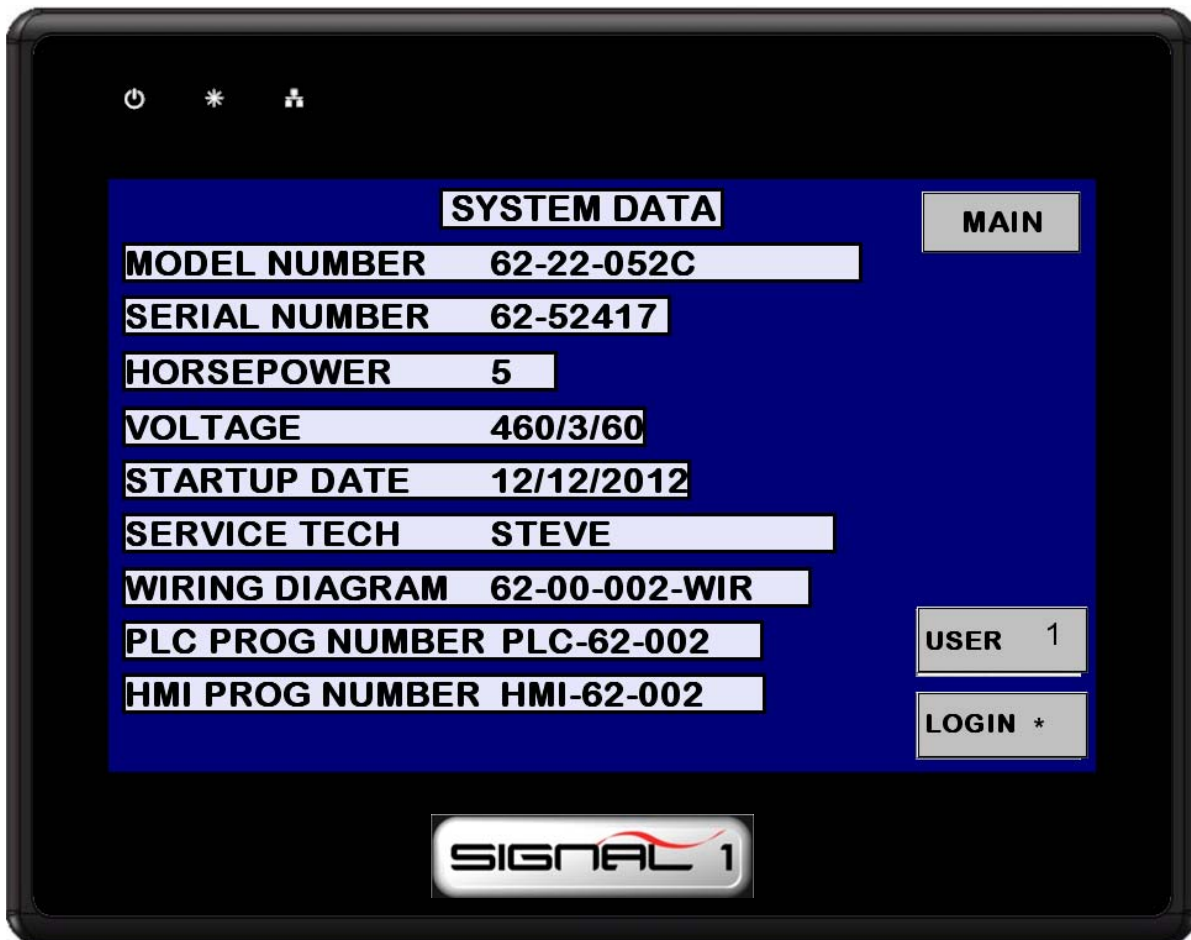

3.0 Control Panel (Continued)

3.3 Control Buttons

3.3.14 “PARTS MENU” Button

The “Parts Menu” button displays routine maintenance parts required when performing scheduled maintenance.

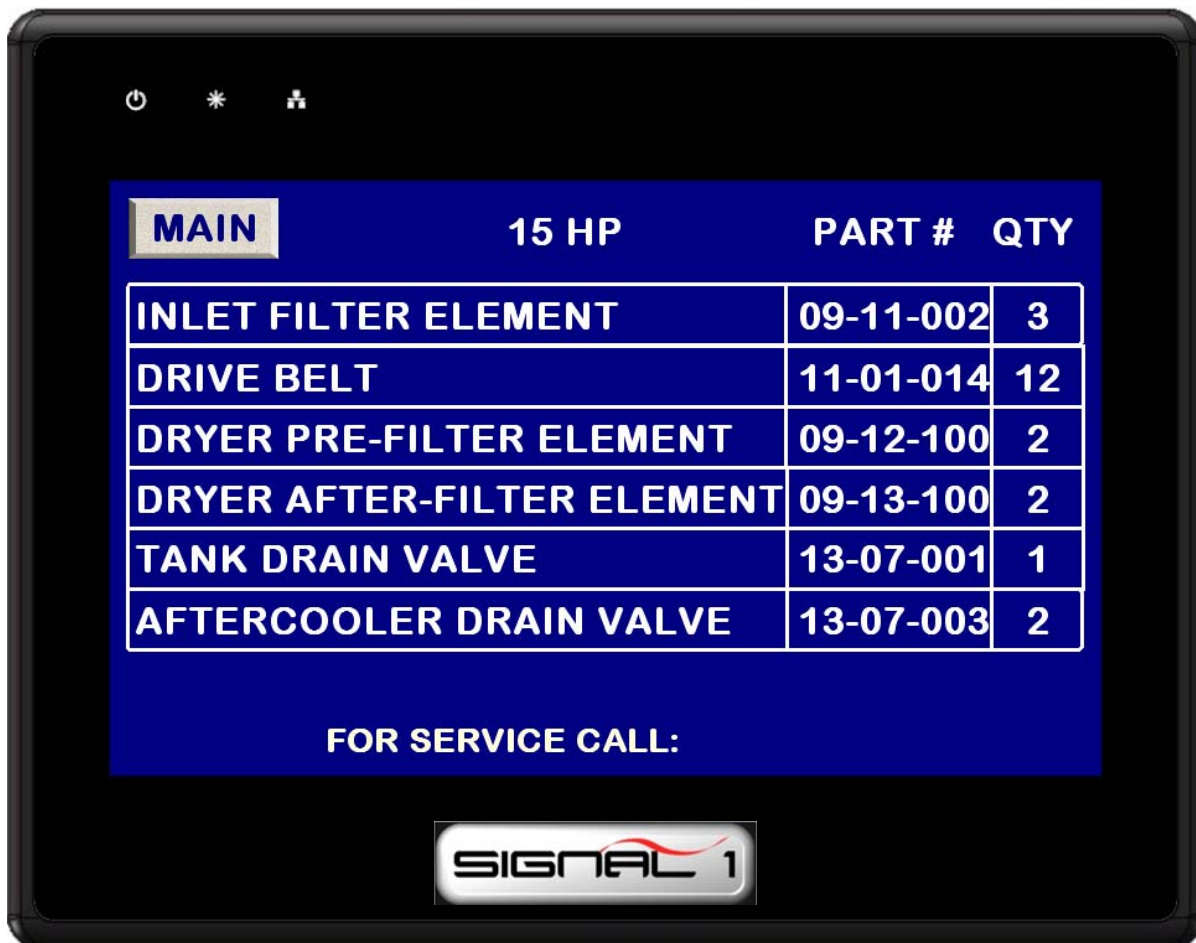

3.0 Control Panel (Continued)

3.3 Control Buttons

3.3.15 – “SYSTEM SERVICE and PUMP SERVICE” Buttons

1. Select “USER #” button and enter “3” and press “enter”.
2. Select “LOGIN” button and enter “350” and press “enter”.
3. Press “RESET” button next to item requiring maintenance red light will be flashing.

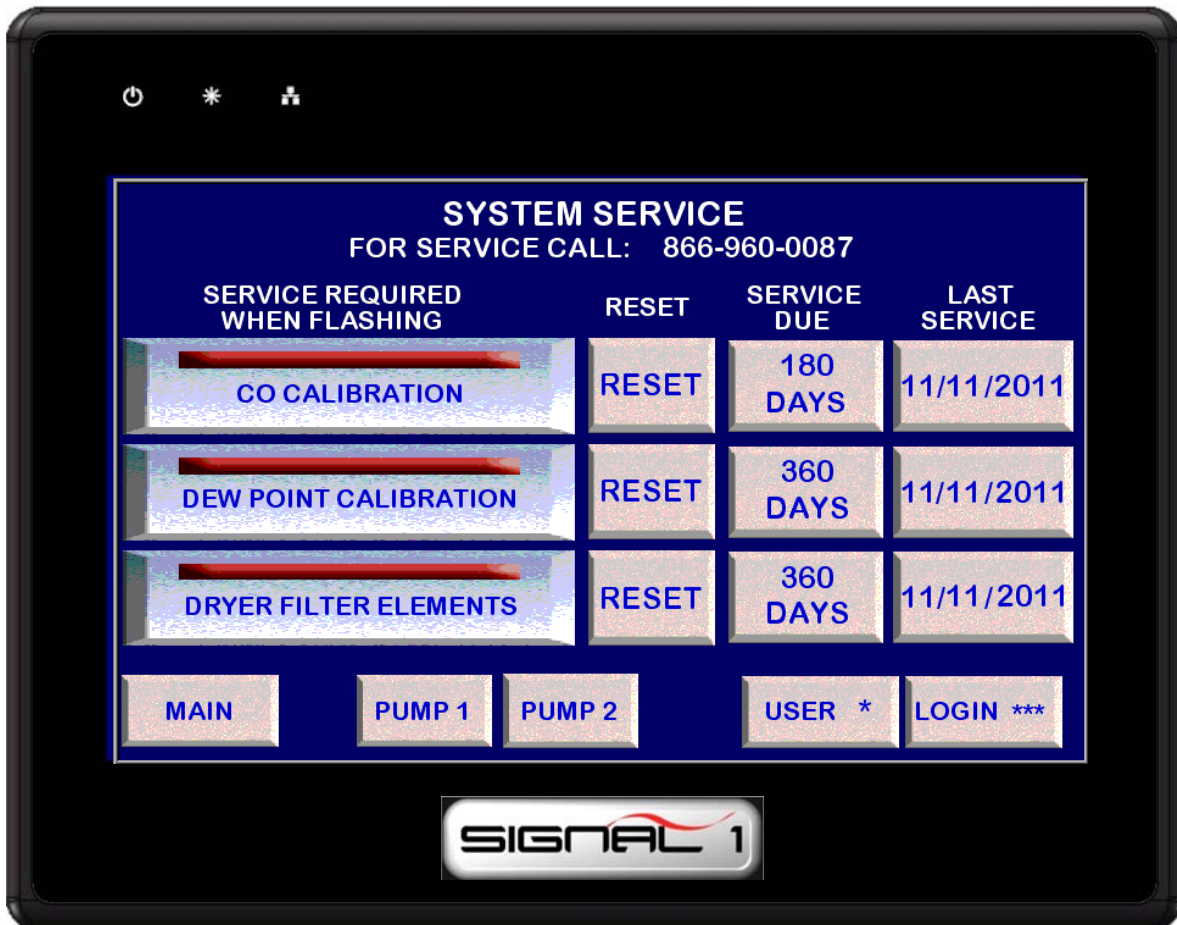

4. Screen to right will display press “YES” to reset maintenance performed. Service due date and Last Service date will reset.

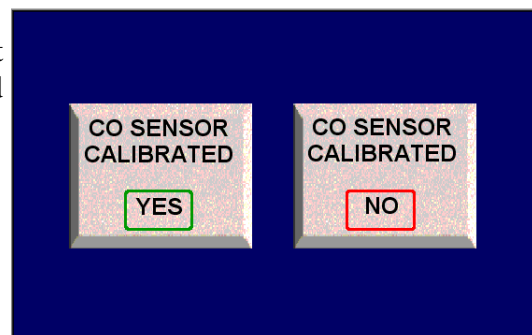

3.0 Control Panel (Continued)

3.3 Control Buttons

3.3.16 – “PRESSURE SETTING” Button

Pressure setting screen allows changing of cut in and cut out set points. Pressing restore defaults will change all settings back to factory default setting.

1. Select “USER #” button. Enter “2” and select “enter”.
2. Select “LOGIN” button. Enter “327” and select “enter”.
3. Press setting to be changed and screen to right will display. Enter pressure setting desired then “ENT”.
4. Pressing “RESTORE DEFAULTS” at anytime will change all settings to original factory settings.

.	/	-
1	2	3
4	5	6
7	8	9
ENT	0	CLR



3.0 Control Panel (Continued)

3.3 Control Buttons

3.3.17 – “TROUBLE SHOOTING GUIDE” Button

The “TROUBLE SHOOTING GUIDE” button will display a window screen listing possible solutions to problems that may occur (see example below). Individual screens can also be accessed by pressing any alarm indicator that is an alarm condition.





4.0 System Operation

4.1 Prestart-up

The contractor should notify **Patton's Medical** two weeks prior to start-up date to schedule an appointment for an authorized technician to review the installation prior to start-up.

WARNING:

Prior to putting the Medical Air system into use, the medical facility must have a Certifier perform all installation tests as specified in NFPA 99. The medical facility is also responsible for ensuring that the Medical Air meets the minimum requirements for Medical Air as specified in NFPA 99.

CAUTION: Failure to install the unit properly and have an authorized technician from **Patton's Medical** start-up the system can void the manufacturer's warranties.

WARNING:

Have more than one person on hand during prestart-up and start-up procedures to ensure safety and to facilitate certain checks.

Prestart-up and start-up procedures should be performed for a new installation or when major maintenance has been performed.

The main power source to the control panel should be OFF for the duration of the visual inspection.

Ensure that the equipment is installed on a solid level surface. Walk around the system to ensure that there is enough clearance on all sides to perform operational checks/actions and maintenance. The temperature of the area containing the modules should be approximately 70°F (21.1°C) with a minimum ambient temperature of 40°F (4.4°C) and a maximum ambient temperature of 104°F (40°C).

Check the inlet piping for proper size and connection to the compressor modules.

Check all piping system joints that might have come loose during shipment and installation to ensure they are tight.

Check the air receiver, dryers, controls, and compressors for damage.

Check the drain valves on the air receiver and compressor modules.

4.0 System Operation (continued)

4.2 Initial Start-up

CAUTION: Complete the prestart-up procedure before continuing with the initial start-up procedure

WARNING:

To prevent electrical shock, ensure that ALL electrical power to the system is OFF, including the disconnect switches and H-O-A switches on the control panel. The facility's supply circuit breaker should also be locked out.

NOTE: DO NOT ADD OIL TO THE COMPRESSOR. The design of the compressor is totally **oil-less**. It is not necessary to fill the crankcases with oil.

WARNING:

Ensure that all loose articles, packing material, and tools are clear of the system.

Set the H-O-A switches are to "O" (OFF).

Check all voltages supplied to the system to ensure they are the required value and phases needed by the control panel.

Open the inlet isolation valve on each compressor.

Open the outlet isolation valve on each compressor.

Open the receiver isolation valves.

Close the receiver bypass valve.

Close the dew point sensor isolation valve.

Close the inlet and outlet valves on **both** dryer/filter/regulator assemblies.

Close the outlet isolation valve.

Apply power to the system and turn the disconnect switches to "On".

4.0 System Operation (continued)

4.2 Initial Start-up (continued)

Check for correct direction of rotation of each compressor by momentarily turning the H-O-A switch to the “Hand” position and observing rotation.

WARNING:
DO NOT RUN THE COMPRESSOR BACKWARDS!

Rotation direction arrows are located on the belt guard (rotation is clockwise, facing the compressor pulley). Correct the rotation, if required, by switching the motor leads at the starter.

WARNING:
REMOVE POWER BEFORE WORKING ON ANY ELECTRICAL CONNECTIONS.

Start each compressor by turning the H-O-A switch to the “Auto” position. Allow each compressor module to operate for a short time (15 to 30 seconds) and check for any unusual noises or vibrations.

If everything appears normal, allow each compressor to run in the “Auto” mode until pressure builds in the air receiver. The lag compressor should stop when the pressure reading reaches 95 psig. Pushing the reset button on the control panel can now silence the lag alarm. The lead compressor should stop when the panel gauge pressure reaches 100 psig. Check for any leaks in the piping up to the inlet isolation valves of the dryers. Repair leaks, if needed.

Open the inlet isolation valve on one of the dryers. One of the dryer towers should be online at line pressure. The other dryer tower will be at 0 psig and airflow will be coming from the dryer purge exhaust muffler. It is possible that the outlet dew point may be low enough to activate the purge saving feature at start-up because of preliminary testing of the dryer at the factory. If the “Demand Purge” feature is activated, then both dryer towers will be at the same pressure as the control panel gauge and there will be no flow from the dryer purge exhaust muffler. Check for air leaks.

Adjust the pressure regulator to the desired pressure setting.

Open the outlet isolation valve of the dryer/filter/regulator group. Check for air leaks.

Open the dew point sensor isolation valve.

4.0 System Operation (continued)

4.2 Initial Start-up (continued)

Slowly open the outlet isolation valve to allow air to flow out to the hospital.

Adjust the pressure regulator setting if necessary.

If everything appears normal, open the inlet isolation valve of the other dryer/filter/regulator assembly. If the dryer pressures appear as expected, open the dryer/filter/regulator outlet isolation valve. Close the other dryer/filter/regulator inlet and outlet isolation valves.

CAUTION: Only one dryer/filter/regulator group should be on line at a time.

Adjust the pressure regulator to the desired pressure.

Adjust the pressure regulator setting, if necessary.

The dryer should purge until the dew point monitor reading is below minus 10°C. If dew point is below minus 10°C; both towers of the on-line dryer will be at the same pressure as the control panel pressure gauge.

Observe the system for normal operation.

4.3 Normal Start-up

Hospital shutoff valve - CLOSED.

Isolation (shutoff) valves - OPEN.

Receiver bypass valve - CLOSED.

One air dryer off line with valves CLOSED; the other air dryer on-line with the valves OPEN.

Main electrical power - ON.

Disconnect switches - ON.

H-O-A switches - AUTO (starting all compressor units).

Pressure gauge increasing to 100 psi.

4.0 System Operation (continued)

4.3 Normal Start-up (continued)

Check that each compressor shuts down as it reaches its off-limit pressure.

Check that the mainline regulator is set for the desired output pressure and adjust if necessary.

Slowly open the hospital shutoff valve.

Note: Opening the hospital valve may cause a pressure demand that brings the lag compressors back on-line. This is a normal sequence.

Note: The Medical Air system is now on-line and in the Normal Operating Mode (lead/lag operation).

4.4 Normal Operation

3.4.1 Controls

During normal operation, all H-O-A switches should be turned to the “Auto” position so that the PLC can effectively control the system. The PLC monitors the system pressure transducer, starts and stops the compressors depending on the pressure transducer’s changing conditions and automatically alternates the lead position between compressor units.

In a typical **duplex** system, one compressor will be able to handle the system load. The PLC will signal the lead compressor to start when the lead pressure setting closes at 90 psig with falling system pressure. If one compressor can carry the load, then the system pressure will rise to 100 psig and turn off. When the system pressure drops again, the PLC will automatically sequence the lead role to the other compressor and will start it. If the lead compressor runs continuously in lead for more than 15 minutes, the PLC will automatically sequence the compressor attempting to evenly distribute the run time among all available compressors. If during operation, the second compressor is required to come on in addition to the lead compressor, the PLC will turn on the “Lag Alarm”.

4.0 System Operation (continued)

4.4 Normal Operation (continued)

4.4.1 Controls (continued)

In a **triplex** or **quadruplex** system, the operation is very similar to the duplex operation described above with the following differences. For each additional compressor, there is an additional pressure setting (see Table 3-1 below). With a triplex or a quadruplex system, the lag unit running alarm may not necessarily correspond to the third or fourth compressor coming on. To determine when the PLC turns on the lag alarm, it counts the number of units in the “Auto” position and makes a decision based on the pressure conditions. For example, in a quadruplex system with only 2 H-O-A switches in the “Auto” position, the lag alarm will turn on when the second unit is turned on.

Note: For a compressor to be considered available to the system (through the PLC), its H-O-A switch must be in the “Auto” position.

Table 3-1 System Pressure Settings

System Pressure Switch	Start (Close)	Stop (Open)
Lead	90 psig	100 psig
Lag 1	85 psig	95 psig
Lag 2 - Tpx and Qpx Only	80 psig	90 psig
Lag 3 - Qpx Only	75 psig	85 psig

For maintenance, or other reasons, the compressors can operate in the “Hand” position. In this condition, the compressor in the “Hand” position will start and stop depending on the back-up pressure switch condition.

Note: Any compressor in the “Hand” position will start and stop when the back-up switch closes or opens.

4.4.2 Dryers

This fully automatic, heat-less type dryer alternately cycles the compressed air flow through two desiccant charged vessels where the gas’ vaporous moisture content is adsorbed. One desiccant vessel is always on-line in a **drying cycle** throughout normal dryer operation. The opposite, off-line vessel is in a **regeneration cycle** for removal of the previously adsorbed moisture content, or in a purge saving cycle at line pressure.

4.0 System Operation (continued)

4.4 Normal Operation (continued)

4.4.2 Dryers (continued)

When the dryer selector switch is in the “**Manual Purge**” position, the dryer will shift towers every 120 seconds. At normal operating conditions, one tower is approximately 100 psig and the other tower is at 0 psig. Any condition other than this is not normal and will cause a high dew point condition. During tower changeover, the online chamber will exhaust, and the chamber that is regenerating (purging) will come to line pressure. There is a 50 second re-pressurization cycle. If the selector switch is on the manual purge cycle, the dryer will use 15% of the system capacity to purge the dryer.

When the dryer selector switch is in the “**Demand Purge**” position, the dryer purge is controlled by the dew point monitor and purging depends on the dew point condition. When the dew point reading is above the set point of -10°C , the dryer will function normally (one tower at 100 psig, one tower at 0 psig). When the dew point is below the set point of -10°C on the dew point monitor, closing the exhaust valve turns off the purge air. In this condition, both towers will be approximately 100 psig and the dryer will continue to shift towers. However, the off line chamber will remain at 100 psig until the dew point is above -10°C .

4.5 Normal Shutdown

H-O-A switches-OFF

Disconnect switches-OFF

Main power source-OFF

Hospital shutoff valve-CLOSED

Air receiver manual tank drain-OPEN

Pressure gauge decreasing to 0 psi

Close air receiver manual tank drain when pressure decreases to 0 psi

4.0 System Operation (continued)

4.6 Emergency Shutdown / Alarms

The following conditions may arise during operation.

High Air Temperature Shutdown - This will shut down the compressor in question and will not re-start until the alarm reset button is pressed on the main control panel. Before allowing the unit to re-start, the condition should be checked (see “Compressor runs hot” in the Troubleshooting Section 5.0). Even after pushing the button, the unit may not re-start, depending on system sequencing and system pressure.

Motor Overload Shutdown - This will shut down the compressor in question and will not re-start until the reset button on the starter inside the main control cabinet is reset. See “Motor overheating” in the Troubleshooting Section 5.0.

Lag Unit Running Alarm - This alarm will activate if the last available compressor unit comes on. In the case of a duplex system, it will activate when the second compressor turns on or the lag pressure setting is reached. To silence the alarm, press the alarm reset button. In the event the lag alarm is persistent, check to see if any leaks or valves are open downstream or reduce the system load.

5.0 Troubleshooting

Problem	Possible Causes	Solution
Failure to start	Main power disconnected	Turn on main power
	Power failure	Restore power
	Main fuse blown	Replace fuse
	Fuse blown in control circuit	Replace fuse
	Overload tripped on starter	Reset & check for system overload
	High temperature switch activated	Allow unit to cool; reset switch & check for over temperature condition
Power failure	Main fuse blown	Replace fuse
	Fuse blown in control circuit	Replace fuse
Compressor shuts off unexpectedly	Overload tripped on starter	Reset & check for system overload
	Pressure setting out of adjustment	Check transducer
	High temperature switch activated	Allow unit to cool; reset switch & check for over temperature condition
High temperature alarm	High temperature switch activated	Allow unit to cool; reset switch & check for over temperature condition
Motor overload	Low voltage	Check for proper supply voltage
	Defective motor	Contact Patton's Medical

5.0 Troubleshooting (continued)

Problem	Possible Causes	Solution
Compressor runs hot	Incorrect pressure setting	Adjust pressure setting
	Faulty check valve	Contact Patton's Medical
	Check if valve or line to receiver is leaking or plugged	Replace if necessary
	Intake filter clogged	Clean or replace
Low discharge pressure	System piping leaks	Repair leaks
	Solenoid stuck open	Check electrical connections
	Belts slipping	Adjust tension
	Intake filter clogged	Clean or replace
Compressor cycles too often	System undersized	Contact Patton's Medical
	Incorrect pressure setting	Adjust pressure setting
	Faulty pressure transducer	Replace transducer
	System piping leaks	Repair leaks
	Check valve or line to receiver is leaking or plugged	Replace if necessary
	Both dryers on line	Valve off one dryer
	Water in air receiver	Drain air receiver
Compressor won't shut off	Pressure setting out of adjustment	Adjust

For any operational problems not listed here, please contact your local **Patton's Medical Service** representative.
1-866-960-0087

5.0 Troubleshooting (continued)

Problem	Possible Causes	Solution
Excessive belt wear	Belt tension Belt alignment	Adjust tension Realign compressor & motor sheaves
Abnormal noise	Mounting bolts loose Belt tension	Tighten bolts Adjust tension

6.0 Maintenance

6.1 Maintenance Schedule

WARNING:
BEFORE STARTING ANY MAINTENANCE PROCEDURES,
DISCONNECT ALL POWER TO THE PACKAGE.

Release all pressure from the package before removing, loosening, or servicing any covers, guards, fittings, connections, or other devices.

Never perform any maintenance functions while the unit is in operation.

Maintenance Schedule

Item	Frequency	Action
Check condensate in tank	Daily	Open manual drain valve: check auto drain
Check operation of safety valve	Weekly	Manually release pressure
Check inlet air filter(s)	Weekly	Inspect and clean or replace
Check nuts, bolts, fittings, etc.	Monthly	Inspect and tighten
Check belt tension	Monthly	Inspect and tighten or replace
Check compressor piston rings and rider rings	Every 3,000 hrs.	Inspect
Check compressor valve plates and valve parts 1 - 20 HP	Every 12,000 hrs.	Inspect and repair or replace
Piston rings and rider rings 1 - 7.5 HP 10 - 20 HP	Every 10,000 hrs. Every 8,000 hrs.	Replace
Ball and needle bearings 1 - 7.5 HP 10 - 20 HP	Every 10,000 hrs. Every 8,000 hrs	Replace



Oil-Less Reciprocating Medical Air System

6.0 Maintenance (continued)

6.1 Maintenance Schedule (continued)

Item	Frequency	Action
Check flow through orifice of dew point sensor	Every 6 months	Check for flow blockage
Check dew point sensor accuracy	Every 12 months	Verify dew point sensor accuracy (contact Patton's Medical)
Calibrate CO monitor	Every 12 months	
Replace pre-filters & after-filters	Yearly	Replace filter elements
Replace Dryer Desiccant	6 Years	

6.2 Replacement Filter Elements (Individual)

DUPLEX								
HP	Inlet	Ea.	Crankcase	Ea.	Pre-filter	Ea.	After-filter	Ea.
1	09-11-001	2	50-06-001	2	09-12-100	2	09-13-100	2
2-10	09-11-001	2	50-06-002	2	09-12-100	2	09-13-100	2
15	09-11-002	2	50-06-002	2	09-12-100	2	09-13-100	2
20	09-11-002	2	50-06-004	4	09-12-100	2	09-13-100	2
TRIPLEX								
7.5-10	09-11-001	3	50-06-002	3	09-12-100	2	09-13-100	2
15	09-11-002	3	50-06-002	3	09-12-101	2	09-13-101	2
20	09-11-002	3	50-06-004	6	09-12-102	2	09-13-102	2
QUAD								
7.5-10	09-11-001	4	50-06-002	4	09-12-101	2	09-13-101	2
15	09-11-002	4	50-06-002	4	09-12-102	2	09-13-102	2
20	09-11-002	4	50-06-004	8	09-12-103	2	09-13-103	2

6.0 Maintenance (continued)

PENTAPLEX								
HP	Inlet	Ea.	Crankcase	Ea.	Pre-filter	Ea.	After-filter	Ea.
15	09-11-002	5	50-06-002	10	09-12-103	2	09-13-103	2
20	09-11-002	5	50-06-004	10	09-12-104	2	09-13-104	2
HEXAPLEX								
15	09-11-002	6	50-06-002	12	09-12-104	2	09-13-104	2
20	09-11-002	6	50-06-004	12	09-12-105	2	09-13-105	2

6.2 Replacement Filter Elements (Complete Sets)

HP	Configuration	Kit Part No.	Consists of:
1	Duplex	40-05-049	Inlet filter(s) Crankcase filter(s) Prefilter(s) Afterfilter(s)
2-5		40-05-050	
7.5-10		40-05-051	
15		40-05-052	
20		40-05-053	
7.5	Triplex	40-05-054	
10		40-05-055	
15		40-05-056	
20		40-05-057	
7.5-10	Quad	40-05-058	
15		40-05-059	
20		40-05-060	
15	Pentaplex	40-05-061	
20		40-05-062	
15	Hexaplex	40-05-063	
20		40-05-064	

Complete sets of replacement filter element kits include required quantities of filter elements for a given system.

6.0 Maintenance (continued)

6.3 Maintenance Kits

Kit Description	HP	Kit Number	Consists of:
Complete Overhaul	1	40-01-001G	Crankshaft main bearings Connecting rod assembly Ring overhaul kit Bearing box gasket Valve kit(s)
	2	40-01-002G	
	3	40-01-003G	
	5	40-01-004G	
	7.5	40-01-005G	
	10	40-01-006G	
	15	40-01-007G	
	20	40-01-008V	
Ring Overhaul	1	40-02-001G	Rider ring(s) Piston ring(s)
	2	40-02-002G	
	3	40-02-003G	
	5	40-02-004G	
	7.5	40-02-005G	
	10	40-02-006G	
	15	40-02-007G	
	20	40-02-008V	
Valve	1	40-03-001G	Air valve assembly Air valve packing(s) Unloader spring(s) Unloader o-ring(s) Unloader packing(s)
	2	40-03-002G	
	3	40-03-003G	
	5	40-03-004G	
	7.5	40-03-005G	
	10	40-03-006G	
	15	40-03-007G	
	20	40-03-008V	
Gasket	1	40-04-001G	Bearing box gasket Air valve packing(s) Cylinder head packing(s) Unloader packing(s)
	2	40-04-002G	
	3	40-04-003G	
	5	40-04-004G	
	7.5	40-04-005G	
	10	40-04-006G	
	15	40-04-007G	
	20	40-04-008V	

7.0 Inspection/Replacement Procedures

7.1 V-Belts

Narrow type V-belts are used for this unit. Refer to Table 7-1 for the correct size.

7.1.1 Tension Check

Table 7-1 Belt size and Tension (for new belts)

Motor Hp	Tensioning		No. of Belts	Replacement Belt Part Number
	Defl. (in.)	Force (lbs.)		
1	0.20	1.9	1	11-01-015
2	0.18	3.2	1	11-01-017
3	0.25	4.1	1	11-01-018
5	0.27	4.1	1	11-01-028
7 ½	0.39	7.5	1	11-01-004
10	0.38	8.9	1	11-01-022
15	0.43	11.4	1	11-01-005
20	0.41	9.1	2	11-01-022

WARNING:
BEFORE STARTING ANY MAINTENANCE PROCEDURES,
DISCONNECT ALL POWER TO THE PACKAGE.

Release all pressure from the package before removing, loosening, or servicing any covers, guards, fittings, connections, or other devices.

Never perform any maintenance functions while the unit is in operation.

Check the belt tension monthly. Disconnect the main power and remove the belt guard. Deflect each V-belt at the center of the drive span with a spring balance or tension meter at the tension force of Table 7-1. Then check that the average deflections at the proper tension force are approximately the same values as shown in Table 7-1.

7.0 Inspection/Replacement Procedures

7.1 V-Belts (continued)

7.1.2 V-Belt Tension Adjustment

If necessary, adjust the V-belts until the average deflections are within the values shown in Table 7-1.

To tighten the V-belts:

1. Remove the belt guard.
2. Loosen the four bolts securing the motor
3. Adjust the motor away from the pump until the proper tension and alignment is obtained using the 2 adjusting screws. To check for correct alignment, place a straight edge on the faces of the two sheaves. Proper alignment is obtained when all the gaps between the straight edge and the sheaves are minimized and less than 1/16".
4. Check the belt tension again and make sure the tension is similar to the values listed in Table 7-1.
5. Tighten all four bolts on the motor
6. Replace the belt guard **before** operating the machine.

CAUTION: IF THE COMPRESSOR IS OPERATED WITH LOOSE V-BELTS OR IMPROPER SHEAVE ALIGNMENT, THE LIFE OF THE V-BELTS IS SHORTENED. EXCESSIVE TENSION CAN BREAK THE SHAFT OR REDUCE BEARING LIFE. BE SURE TO MAINTAIN PROPER V-BELT TENSION AND ALIGNMENT.

7.0 Inspection/Replacement Procedures

7.1.3 Changing the V-Belts

V-belts should be changed every 8,000 hours under normal operating conditions. If any damage is found, they should be replaced at once. To change the v-belts call the nearest **Patton's Medical** distributor or follow the procedures described below:

To remove the belts:

1. Remove the belt guard.
2. Loosen the four bolts securing the motor.
3. Adjust the motor toward the pump to relieve the tension on the belts.
4. Remove the old belt(s)

Check and clean:

1. Check and clean all of the grooves of both the motor and compressor sheaves.
2. Check the tightness of bolts on the sheave bushings.

Installation of new belts:

1. Confirm the belt type and length.
2. Place the belt(s) into the grooves of both sheaves.
3. Adjust the motor away from the pump until the proper tension and alignment is obtained.
To check for correct alignment, place a straight edge on the faces of the two sheaves. Proper alignment is obtained when all the gaps between the straight edge and the sheaves are minimized and less than 1/16".
4. Check the belt tension again and make sure the tension is similar to the values listed in Table 7-1.
5. Tighten all four bolts on the motor
6. Replace the belt guard **before** operating the machine.

7.0 Inspection/Replacement Procedures

7.2 Air Intake Filter

WARNING:
BEFORE STARTING ANY MAINTENANCE PROCEDURES,
DISCONNECT ALL POWER TO THE PACKAGE.

Release all pressure from the package before removing, loosening, or servicing any covers, guards, fittings, connections, or other devices.

Never perform any maintenance functions while the unit is in operation.

The air intake filter element should be changed every 1 year of operation under normal operating conditions. To change the filter:

1. Turn off the compressor being serviced and lock open the appropriate disconnect switches.
2. Close intake isolation valve
3. Remove the protective cover by loosening the wing nuts on the latches.
4. Remove the element.
5. Clean inside of housing.
6. Insert a new element (note orientation of the element).
7. Replace protective cover and tighten wing nuts on the latches.
8. Open intake isolation valve
9. Turn on the compressor

7.0 Inspection/Replacement Procedures

7.3 Readjustment of Back up Pressure Switch

The cut-out pressure refers to the discharge air pressure at which the unit will stop. The cut-in pressure refers to the discharge air pressure at which the compressor will start and is dictated by the pressure and differential setting of the pressure switch. The standard factory pressure switch settings are shown on the wiring schematic. The cut in pressure setting of the back up switch has to be below the cut in setting of the lag setting on the HMI pressure setting screen.

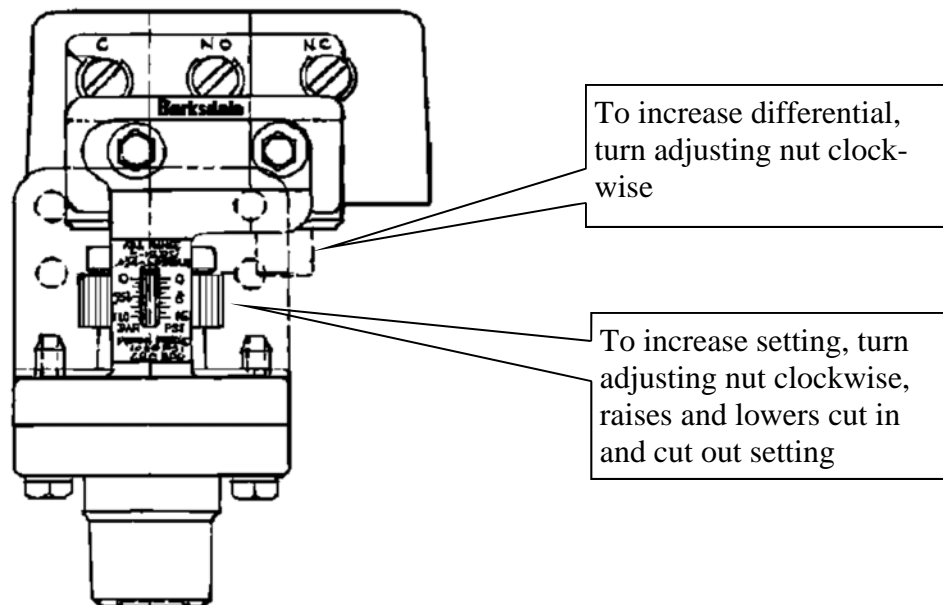

7.0 Inspection/Replacement Procedures (Continued)

7.4 CO Sensor

General Information

The CO transmitter uses an electrochemical sensor to convert a gas concentration into a linear 4–20mA electrical signal, and transmits it over a cable to a controller. It is a loop powered two wire transmitter, where the signal is carried on the “+” wire, along with the supply voltage.

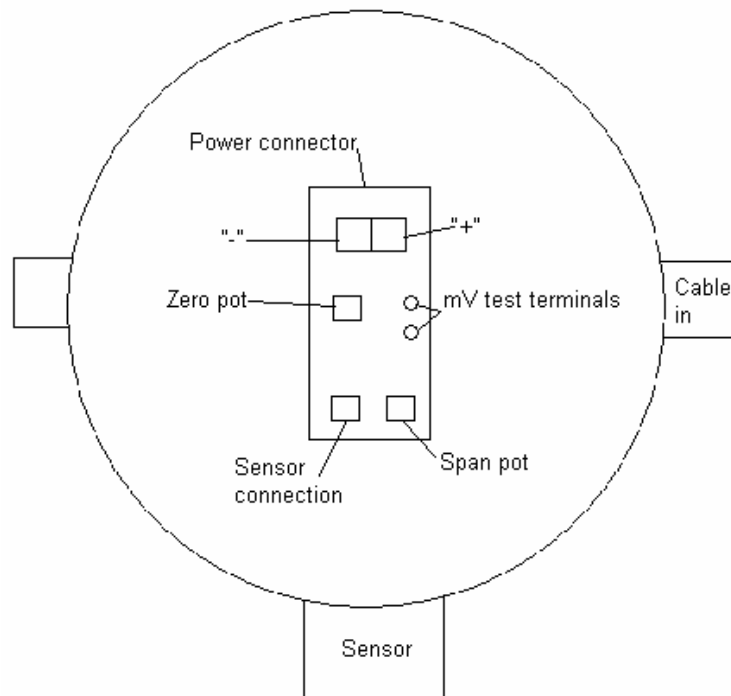

7.0 Inspection/Replacement Procedures (Continued)

7.4 CO Sensor (Continued)

Electrical Connections

The power connector is designed with a “quick disconnect” feature, which simplifies transmitter installation, replacement and service. The connector plug is easily removed from the transmitter by pulling straight up on the top of the power connector. This separates the bottom connection from the wiring connections to the plug. The connector plug is designed to be installed in only one direction (polarized) for safety reasons. Power is connected to the plug (upper portion) of the power connector by securing the stripped ends of the electrical cable using the two screws on the connector plug. Connect the supply wires (10–30 VDC) to the correct terminals on the connector plug (see diagram), and re-attach to the transmitter pc board by pressing back down on the pins from where it was removed.

CAUTION: If the supply wires are reversed on the power connector, the transmitter will produce no current output.

Zero Point Adjustment

The CO transmitter uses a conveniently located set of two test terminals (see diagram) which provide a mV reading that corresponds to the 4–20 mA output. A reading of 40 mV on the test terminals corresponds to 4 mA, and 200 mV corresponds to 20 mA. This feature offers a quick and easy way to verify zero readings and gas response without having to disconnect wires and place current meters in line with the transmitter.

Using a DC voltmeter set to the mV range, place the voltmeter’s leads in the 40–200 mV test terminals on the transmitter pc board. The reading should be approximately 40 mV. If you are unsure if the supply air is clean, flow impurity free air (zero air) into the sensing inlet using a calibration adapter and a 0.5 l pm fixed flow regulator, and allow the mV reading to stabilize. Please contact your Patton’s Medical sales representative for zero gas ordering information if necessary. If the mV reading is not close to 40 mV, then the zero must be adjusted.

To adjust the **ZERO** to **4mA** (40 mV on the test terminals), slowly adjust the zero potentiometer on the transmitter board (see diagram) until a reading of 40 mV on the test terminals is reached (if the zero potentiometer cannot be adjusted to 40 mV, please contact Patton’s Medical service for detailed instructions). This procedure will set the current output from the transmitter to 4 mA (zero).

7.0 Inspection/Replacement Procedures (Continued)

7.4 CO Sensor (Continued)

Sensitivity Check (Calibration)

The transmitter uses a conveniently located set of two test terminals (see diagram) which provide a mV reading that corresponds to the 4-20 mA output. A reading of 40 mV on the test terminals corresponds to 4 mA, and 200 mV corresponds to 20 mA. This feature offers a quick and easy way to verify zero readings and gas response, without having to disconnect wires and place current meters in line with the transmitter.

Using a DC voltmeter set to the mV range, place the voltmeter's leads in the 40–200 mV test terminals on the transmitter pc board. Attach the calibration adapter to the sensing inlet. Flow 20 ppm calibration gas at 0.5 lpm (please contact your Patton's Medical sales representative for calibration gas ordering information if necessary). Allow the gas to flow across the sensor for 2 minutes or until the transmitter signal is stable, then check to see that the mV reading is at 50.6 mV. If the mV reading is not correct, adjust the **Span** potentiometer slowly until a mV reading of 50.6 is obtained (if the span potentiometer cannot be adjusted to the correct mV reading, please contact Patton's Medical service for detailed instructions). After the span adjustment is complete, remove the calibration gas, re-attach the supply air, and allow the transmitter current output to return to 40 mV (zero).

7.0 Inspection/Replacement Procedures (Continued)

7.4 CO Sensor (Continued)

Troubleshooting

Symptom	Possible Cause	Solution
No output	Supply wires reversed	Check wiring for proper polarity
No voltage to transmitter	No power	Check for 10-30 VDC at power connector
No response to gas	Sensor has expired (See below) Sensor wires disconnected Sensor not plugged in correctly	Replace Sensor Check Sensor Wiring Check sensor connection to transmitter pcb
Sensor will not calibrate	Sensor has expired Incorrect or bad span gas	Replace sensor Use correct concentration of span gas

CO Sensor Replacement

Part # 20-01-026-001

1. Unplug sensor connector inside sensor housing.
2. Unscrew sensor coupling.
3. Remove sensor and replace with new one.
4. Plug new sensor into connection inside housing.
5. Reconnect coupling.
6. Recalibrate using correct cal gas.

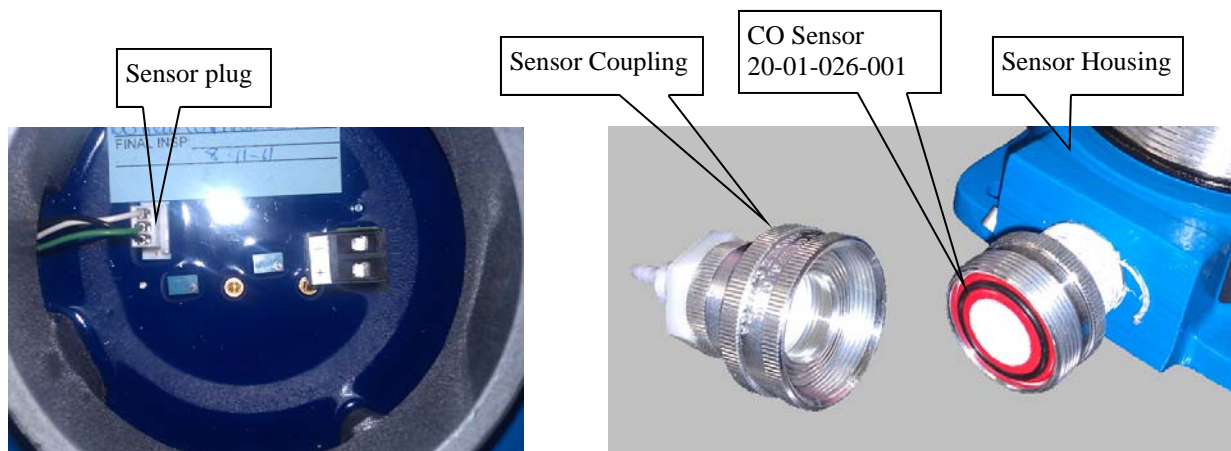

7.0 Inspection/Replacement Procedures (Continued)

7.5 Dew Point Sensor

Sensor is fully factory-tested and calibrated prior to delivery and is supplied with its own Calibration Certificate, providing direct traceability to the National Institute of Standards and Technology. Periodic recalibration is recommended in order to maintain the highest quality of measurement. Patton's Medical recommends that you have your Sensor re-calibrated every 2 years and replaced every 5 years. Patton's Medical offers a re-calibration and exchange sensor program.

Dew Point Sensor Part # 20-02-022

Sensor Replacement

1. Close isolation valve
2. Remove screw from din plug and disconnect
3. Unscrew Dew Point Sensor using Hex on sensor
4. Replace in reverse order (make sure seal ring is between hex on sensor and sample cell)

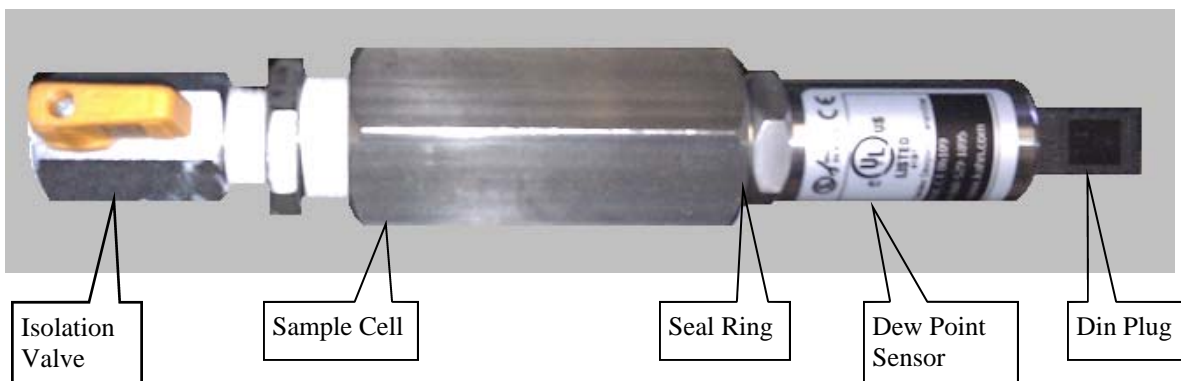

7.0 Inspection/Replacement Procedures (Continued)

7.6 Desiccant Air Dryers

7.6.1 Removing and replacing the front panel

1. Dryer with front fascia panel fitted.
2. Remove single retaining screw.
3. Remove front fascia panel by tilting outwards and downwards.
4. Dryer with front fascia panel removed.
5. Re-fit front fascia panel by insertion of tongue into groove and pushing upwards and inwards.
6. Replace single retaining screw.

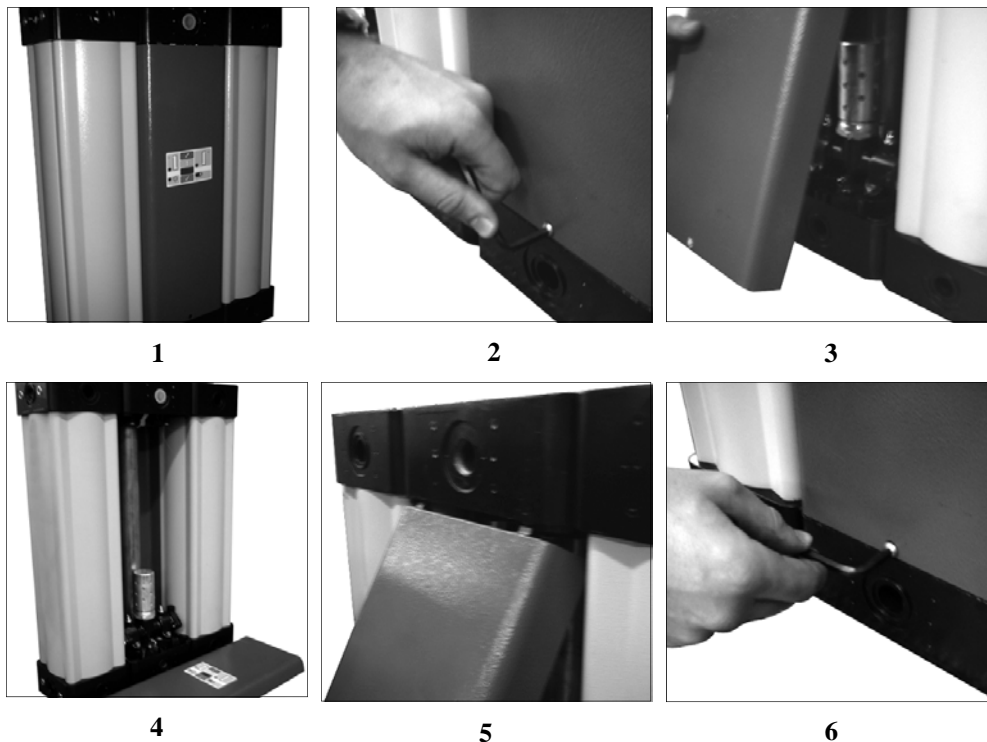

7.0 Inspection/Replacement Procedures (Continued)

7.6 Desiccant Air Dryers (Continued)

7.6.2 Purge plug removal for dryers 8-65 scfm

1. Remove front panel of dryer as described in 7.6.1 and locate purge plug in upper valve block.
2. Remove purge plug screw from upper valve block.
3. Remove purge plug from port in upper valve block downwards.
4. Orifice in purge plug can be cleaned with warm soapy water. Do not use sharp implements or tools.
5. After thoroughly drying the purge plug, push back into port in valve block. Ensure that the o-rings are in place and in good condition.
6. Replace and tighten purge plug screw in upper valve block. Reinstall front panel.



1



2



3

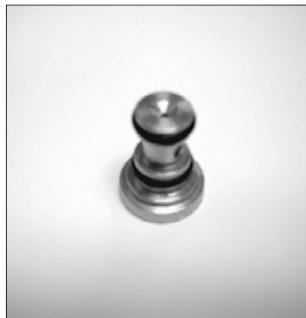

4



5



6

7.0 Inspection/Replacement Procedures (Continued)

7.6 Desiccant Air Dryers (Continued)

7.6.3 Purge plug removal for dryers 85-365 scfm

1. Remove front panel of dryer as described in 7.6.1 and locate purge plug in between the two bonnets.
2. Remove bonnet fixing screws from upper valve block. Remove bonnet from valve manifold block.
3. Remove purge plug from port in bonnet downwards. This will allow the purge plug to be removed.
4. Orifice in purge plug can be cleaned with warm soapy water. Do not use sharp implements or tools.
5. After thoroughly drying the purge plug, ensure that 'O' rings are in place and in good condition. Locate between the bonnets.
6. Replace and tighten bonnets. Reinstall front panel

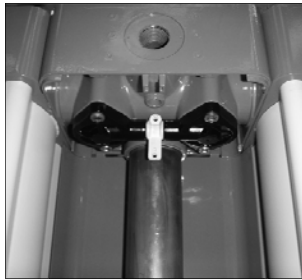

1



2

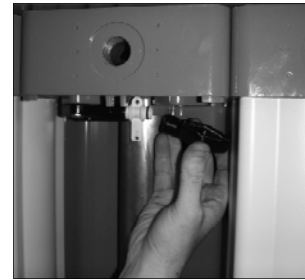

3



4



5



6

7.0 Inspection/Replacement Procedures (Continued)

7.6 Desiccant Air Dryers (Continued)

7.6.4 Cleaning the silencer for dryers 8-65 scfm

1. Remove front panel to access silencer.
2. Disconnect silencer from valve block.
3. Remove silencer from dryer.
4. Clean threads on silencer.
5. Silencer can be thoroughly cleaned in warm soapy water. Do not use sharp instruments or tools.
6. Ensure silencer is thoroughly clean and dry then replace by following the above procedure in reverse. Reinstall front panel.

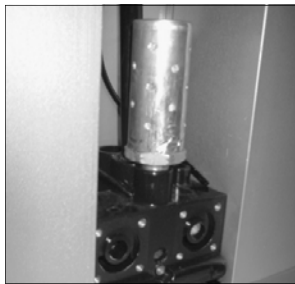

1



2



3

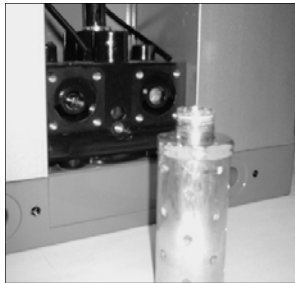

4

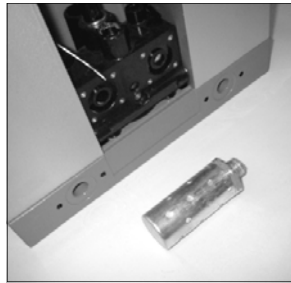

5

7.0 Inspection/Replacement Procedures (Continued)

7.6 Desiccant Air Dryers (Continued)

7.6.5 Cleaning the silencer for dryers 85-365 scfm

1. Remove front panel.
2. Disconnect silencer from valve block.
3. Silencer can be thoroughly cleaned in warm soapy water. Do not use sharp instruments or tools. Clean threads on silencer.
4. Ensure silencer is thoroughly clean and dry then replace by following the above procedure in reverse.



2

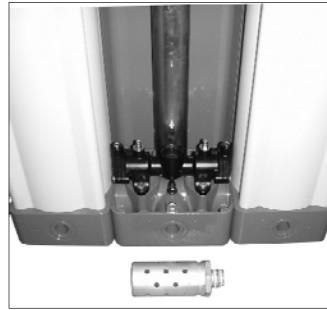

3

7.0 Inspection/Replacement Procedures (Continued)

7.6 Desiccant Air Dryers (Continued)

7.6.6 Replacing the diaphragm on dryers 8-65 scfm

1. Remove front panel and locate position of upper and lower bonnets.
2. Lower bonnets.
3. Remove bonnets by means of four screws.
4. Separate bonnet from valve block.
5. Disconnect tubing from fitting on bonnet.
6. Locate diaphragm assembly to be changed.
7. Remove diaphragm assembly.
8. Diaphragm and bonnet components.
9. Replace diaphragm and bonnet by following above procedure in reverse. Repeat above procedure for all diaphragms on dryer. Reinstall front panel.



1



2



3

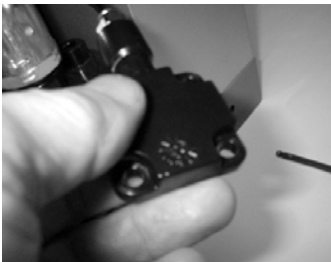

4



5



6



7

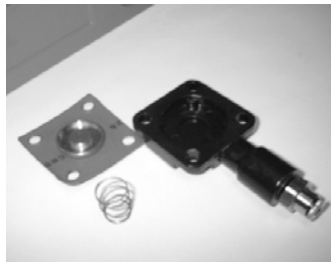

8

7.0 Inspection/Replacement Procedures (Continued)

7.6 Desiccant Air Dryers (Continued)

7.6.7 Replacing the exhaust valve assembly and exhaust shuttles on dryers 85-365 scfm

1. Remove front panel of dryer as described in 7.6.1.
2. Remove the cap screws securing the manifold in position.
3. Remove the manifold, taking care to retrieve the inter face O-rings. The silencer can be removed for maintenance if required.
4. Remove end bonnets, retrieving the O-ring.
5. Remove the exhaust shuttle.
6. Place the shuttle into the bore. Gently fold the seal into the bore while keeping pressure on the end of the shuttle. Refit the end bonnet. The refitting of the manifold is the reverse of removal. Reinstall front panel.

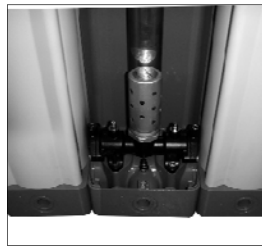

1

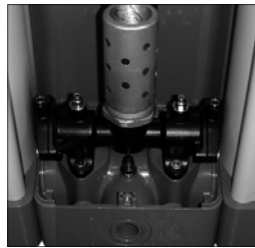

2



3



4



5



6

7.0 Inspection/Replacement Procedures (Continued)

7.6 Desiccant Air Dryers(Continued)

7.6.8 Changing the desiccant cartridges 8-65 CFM

1. Follow the instructions as indicated below.
2. Repeat the procedure as shown in diagram on both towers. Important: do not fully tighten retaining bolts until all towers have been serviced. When complete tighten up all bolts to torque 5nm.
3. Dispose of desiccant cartridges in accordance with local waste regulations.

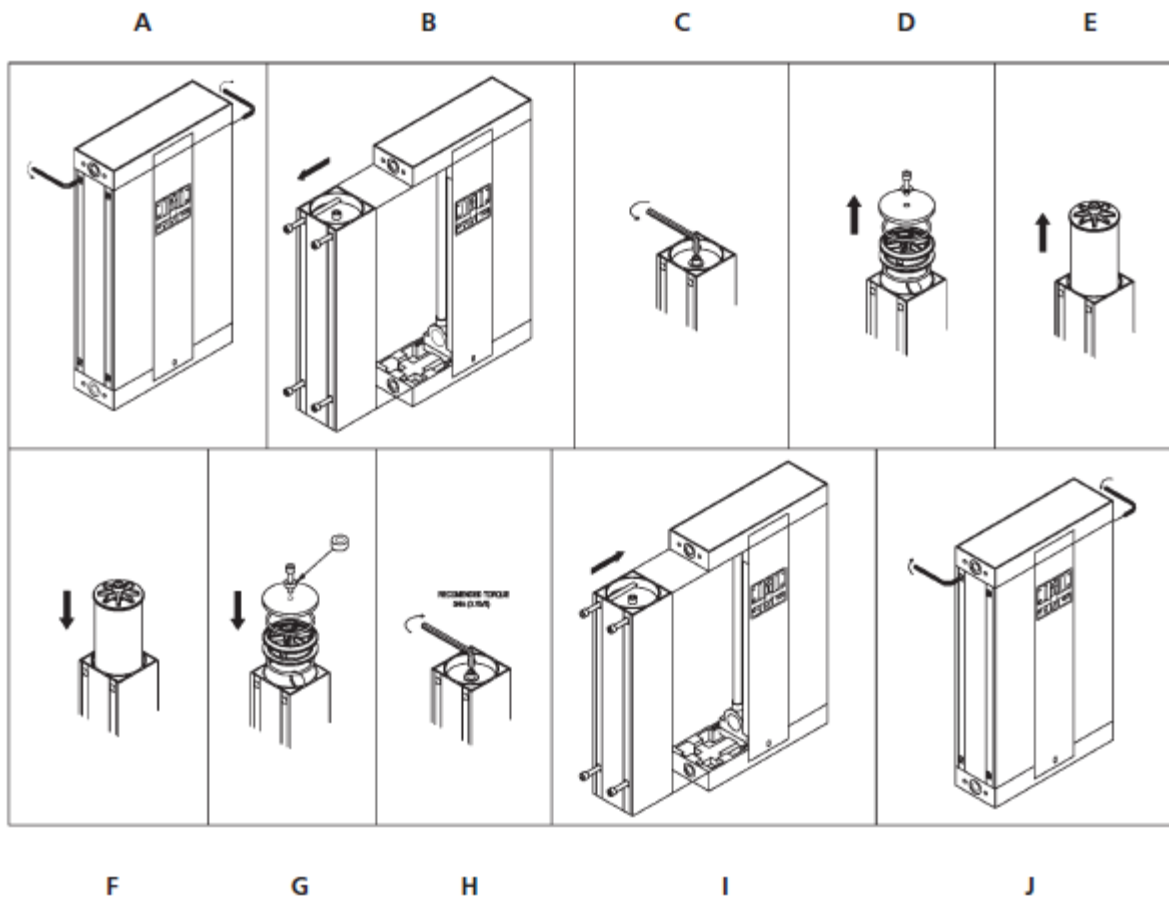

7.0 Inspection/Replacement Procedures (Continued)

7.6 Desiccant Air Dryers (Continued)

7.6.9 Changing the desiccant cartridges 85-365 CFM

1. Remove top cover plate (10)
2. Remove 4 bolts (9)
3. Remove 2 Pressure Housing retaining bolts (8)
4. Remove manifold (5)
5. Remove and replace Desiccant cartridge (7)
6. Make sure all o-rings are in place and replace components in reverse order.

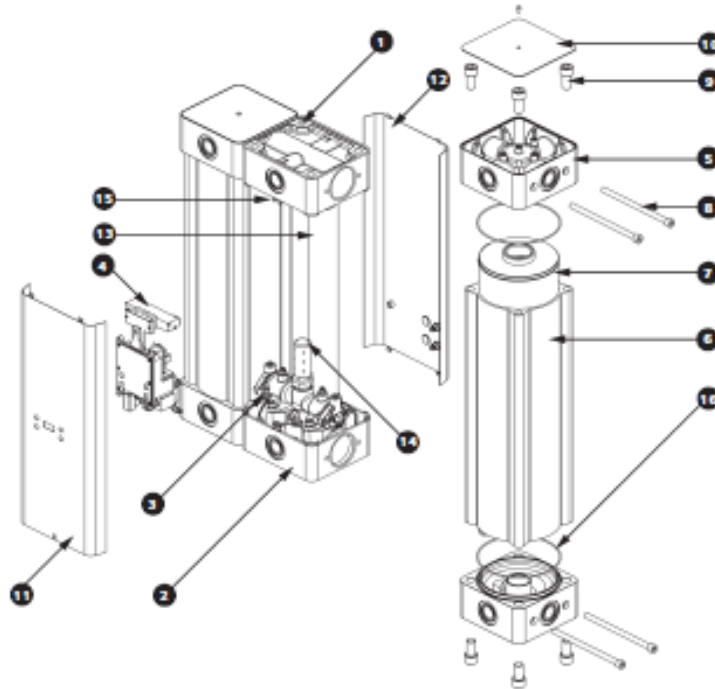

- | | | | |
|---|---|----|--------------------------------|
| 1 | Inlet valve assembly | 10 | Quadra-port manifold top cover |
| 2 | Bottom valve assembly | 11 | Front panel |
| 3 | Exhaust valve assembly | 12 | Back panel |
| 4 | Control/valve unit | 13 | Air transfer down-pipe |
| 5 | Quadra-port manifold | 14 | Silencer |
| 6 | Pressure housing | 15 | Purge plug |
| 7 | Desiccant cartridge c/w dust filter
(where applicable) | 16 | O-ring seal |
| 8 | Pressure housing retaining bolt | | |
| 9 | Quadra-port manifold retaining bolt | | |

7.0 Inspection/Replacement Procedures (Continued)

7.6 Desiccant Air Dryers (Continued)

7.6.10 Dryer Service and fault diagnosis chart

11. Service and fault diagnosis

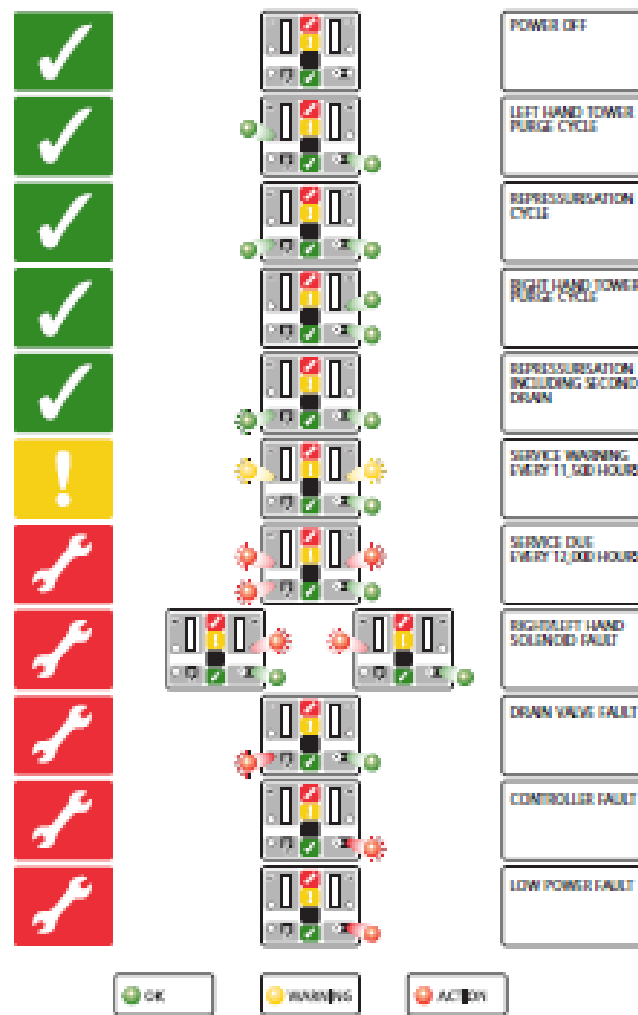



8.0 Replacement Parts

Any information, service or spare parts requests should include the machine serial number and be directed to:

Patton's Medical
3201 South Boulevard
Charlotte, NC 28209

Telephone: 1-866-960-0087
Fax: (704) 525-5148

Medical.service@pattonsmmedical.com

www.pattonsmmedical.com

8.0 Replacement Parts

8.1 G-Series

1 hp

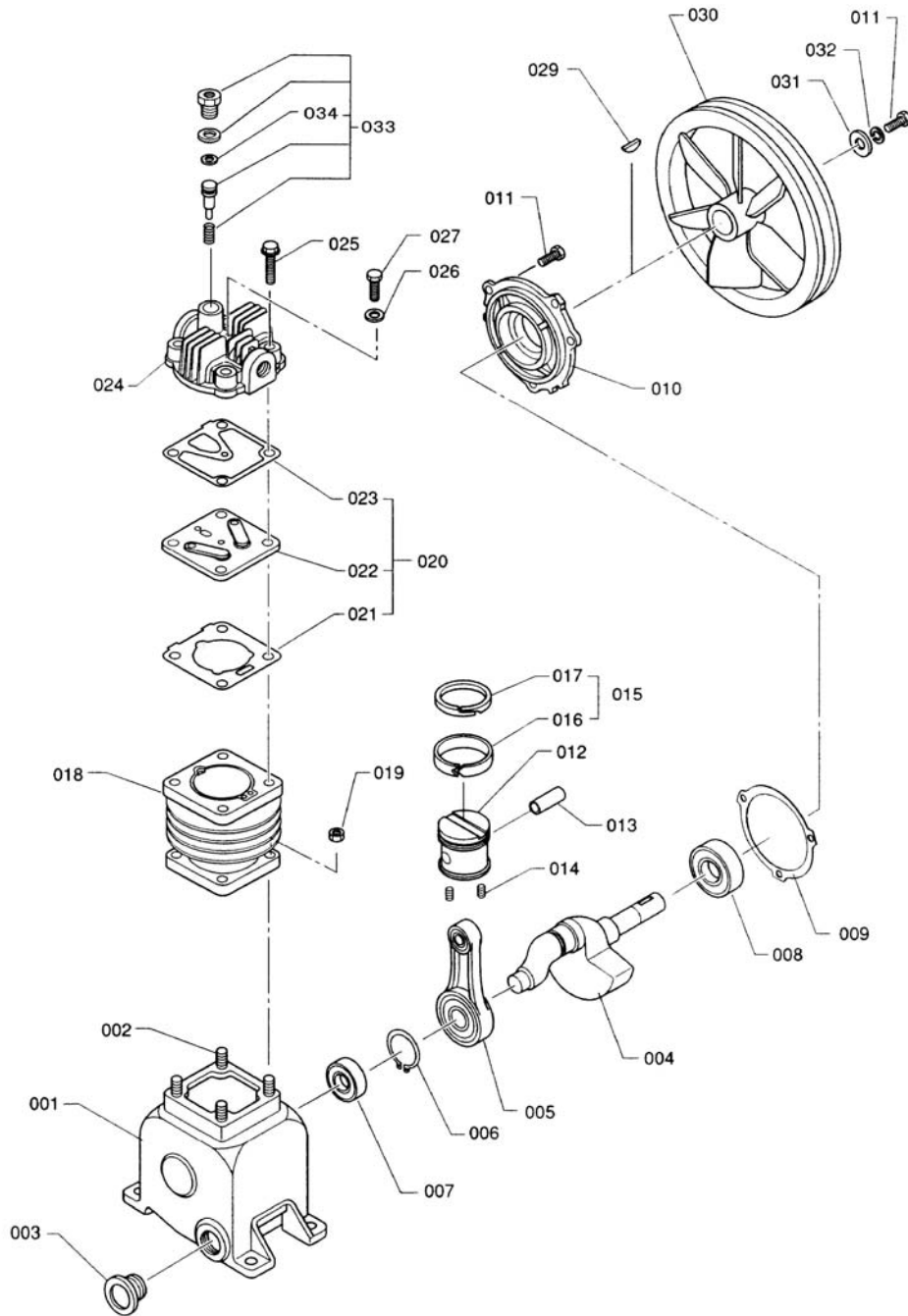

8.0 Replacement Parts

8.1 G-Series

1 hp

Ref.	Part No.	Description	Qty/Unit
003	50-06-001	crank case filter element	1
004	50-20-001	crank shaft	1
005	50-04-001	connecting rod assembly	1
007	50-05-002	crank shaft ball bearing	1
008	50-05-001	crank shaft ball bearing	1
009	50-03-007	bearing box packing	1
010	50-21-001	bearing box	1
012	50-16-010	piston	1
013	50-17-001	piston pin	1
014	50-17-021	bolt	2
015	50-09-001	ring set	1
018	50-13-002	cylinder	1
020	50-01-001	air valve assembly	1
021	50-02-001	air valve packing	1
023	50-07-001	cylinder head packing	1
024	50-14-002	cylinder head (U type)	1
025	50-15-002	head bolt	4
026	50-15-003	packing	1
029	50-23-012	compressor pulley key	1
030	50-23-001	compressor pulley	1
031	50-23-009	compressor pulley washer	1
033	50-11-001	unloader piston set	1

NOTE: Numbered items not shown in the list are not available as individual replacement parts.

8.0 Replacement Parts

8.2 G-Series

2 hp

Ref.	Part No.	Description	Qty/Unit
004	50-20-012	crank shaft	1
005	50-04-002	connecting rod assembly	1
007	50-05-002	crank shaft ball bearing	1
008	50-05-001	crank shaft ball bearing	1
009	50-21-008	bearing box	1
010	50-08-001	oil seal	1
012	50-16-011	piston	1
013	50-17-002	piston pin	1
014	50-17-021	bolt	2
015	50-09-003	ring set	1
018	50-13-004	cylinder	1
020	50-01-003	air valve assembly	1
021	50-02-003	air valve packing	1
023	50-07-003	cylinder head packing	1
025	50-14-004	cylinder head (U type)	1
026	50-15-002	head bolt	4
027	50-15-003	packing	1
029	50-11-001	unloader piston set	1
033	50-23-012	compressor pulley key	1
034	50-23-014	compressor pulley	1
035	50-23-009	compressor pulley washer	1
190	50-16-012	crank case filter assembly	1
191	50-06-011	crank case filter element	1

NOTE: Numbered items not shown in the list are not available as individual replacement parts.

8.0 Replacement Parts

8.3 G-Series

3 hp

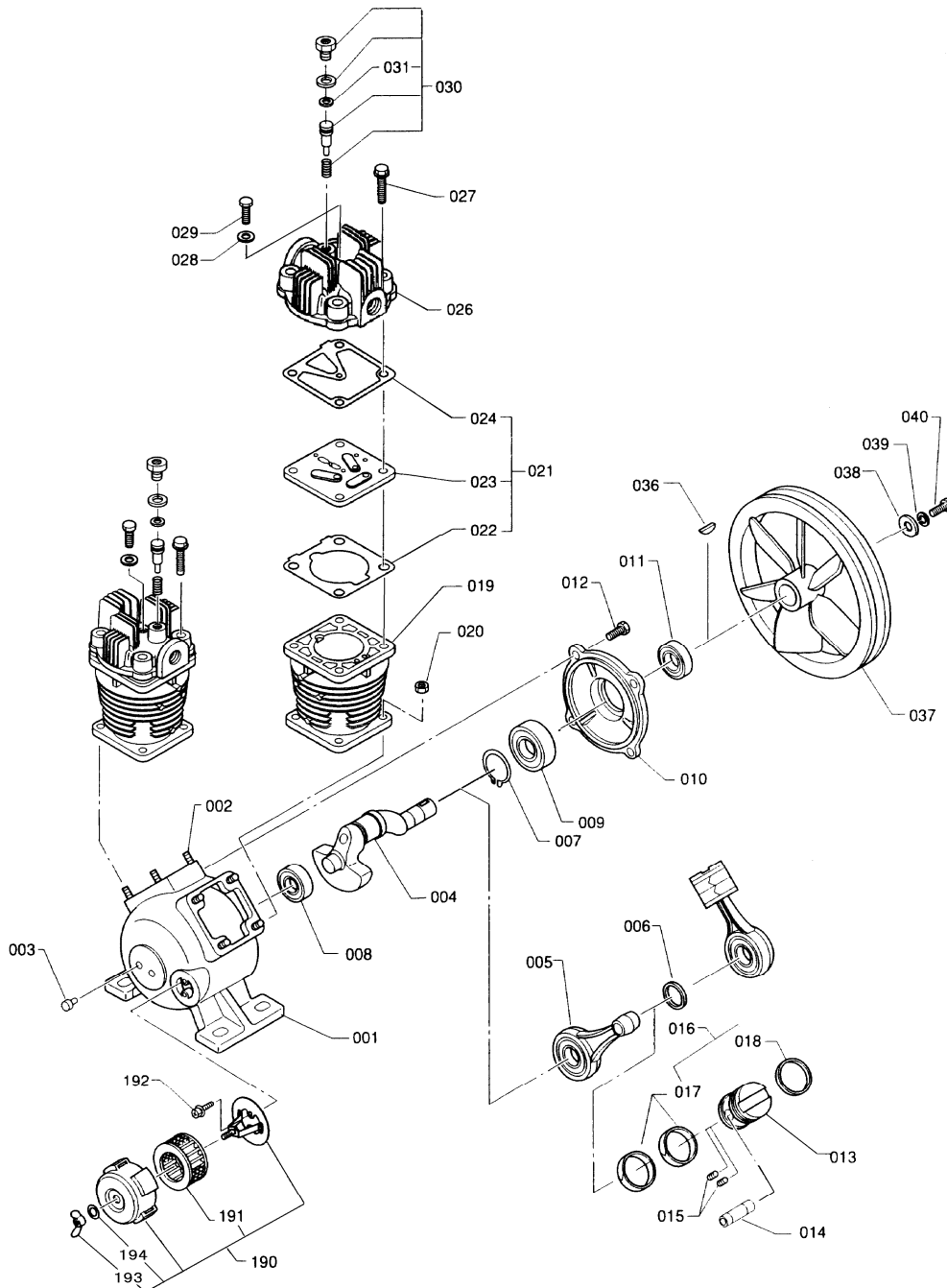

8.0 Replacement Parts

8.3 G-Series

3 hp

Ref.	Part No.	Description	Qty/Unit
004	50-20-013	crank shaft	1
005	50-04-002	connecting rod assembly	2
006	50-22-001	thrust ring	1
008	50-05-002	crank shaft ball bearing	1
009	50-05-001	crank shaft ball bearing	1
010	50-21-008	bearing box	1
011	50-08-001	oil seal	1
013	50-06-012	piston	2
014	50-17-002	piston pin	2
015	50-17-021	bolt	4
016	50-09-003	ring set	2
019	50-13-004	cylinder	2
021	50-01-003	air valve assembly	2
022	50-02-003	air valve packing	2
024	50-07-003	cylinder head packing	2
026	50-14-004	cylinder head (U type)	2
027	50-15-002	head bolt	8
028	50-15-003	packing	2
030	50-11-001	unloader piston set	2
036	50-23-012	compressor pulley key	1
037	50-23-015	compressor pulley	1
038	50-23-009	compressor pulley washer	1
190	50-16-012	crank case filter assembly	1
191	50-06-011	crank case filter element	1

NOTE: Numbered items not shown in the list are not available as individual replacement parts.

8.0 Replacement Parts

8.4 G-Series

5 hp

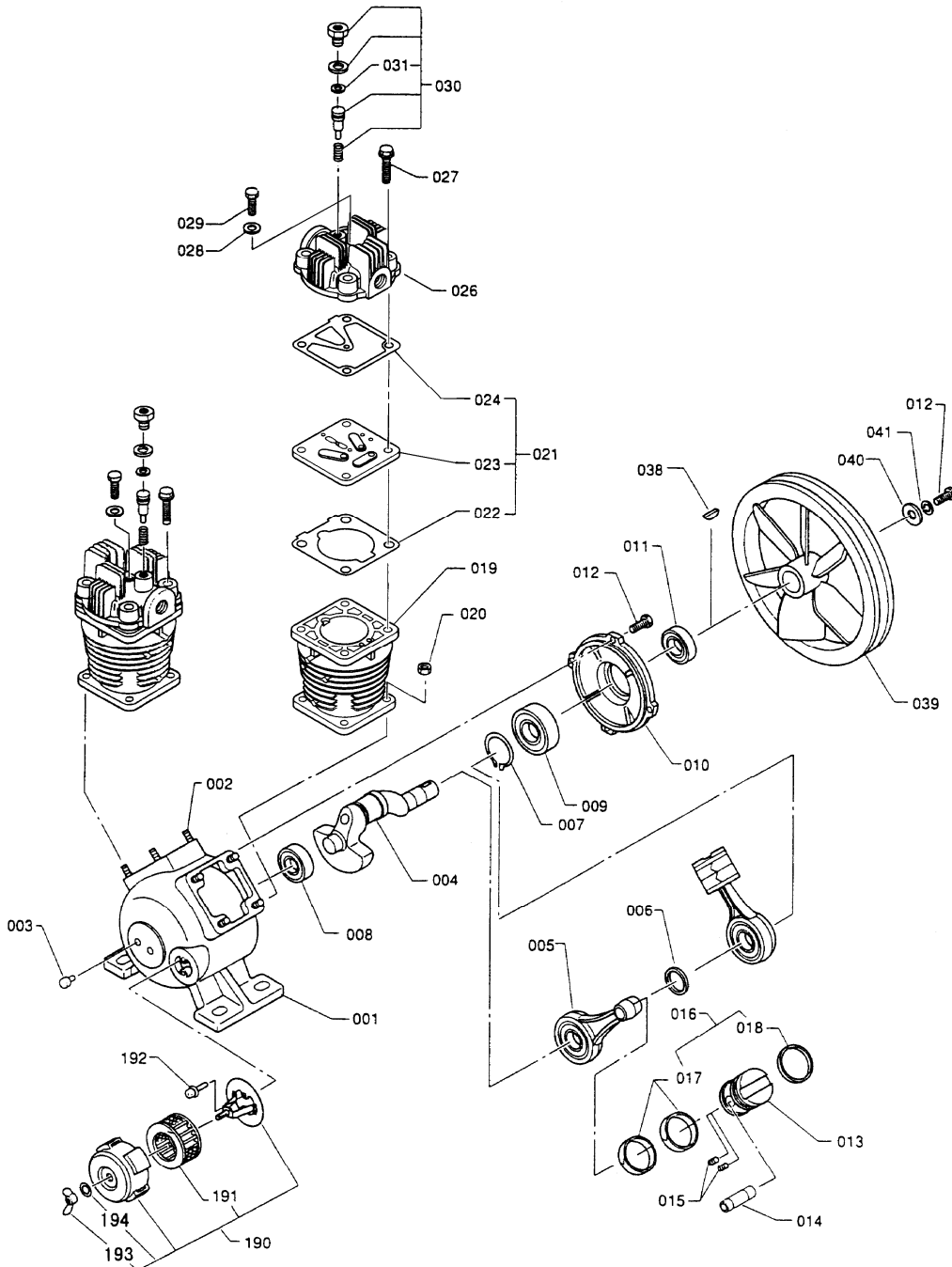

8.0 Replacement Parts

8.4 G-Series

5 hp

Ref.	Part No.	Description	Qty/Unit
004	50-20-014	crank shaft	1
005	50-04-004	connecting rod assembly	2
006	50-22-002	thrust ring	1
008	50-05-006	crank shaft ball bearing	1
009	50-05-004	crank shaft ball bearing	1
010	50-21-009	bearing box	1
011	50-08-002	oil seal	1
013	50-06-012	piston	2
014	50-17-002	piston pin	2
015	50-17-021	bolt	4
016	50-09-003	ring set	2
019	50-13-004	cylinder	2
021	50-01-003	air valve assembly	2
022	50-02-003	air valve packing	2
024	50-07-003	cylinder head packing	2
026	50-14-004	cylinder head U type	2
027	50-15-002	cylinder head bolt	8
028	50-15-003	packing	2
030	50-11-001	unloader piston set	2
038	50-23-013	compressor pulley key	1
039	50-23-004	compressor pulley	1
040	50-23-011	compressor pulley washer	1
190	50-16-012	crank case filter assembly	1
191	50-06-011	crank case filter element	1

NOTE: Numbered items not shown in the list are not available as individual replacement parts.

8.0 Replacement Parts

8.5 G-Series

7.5 hp

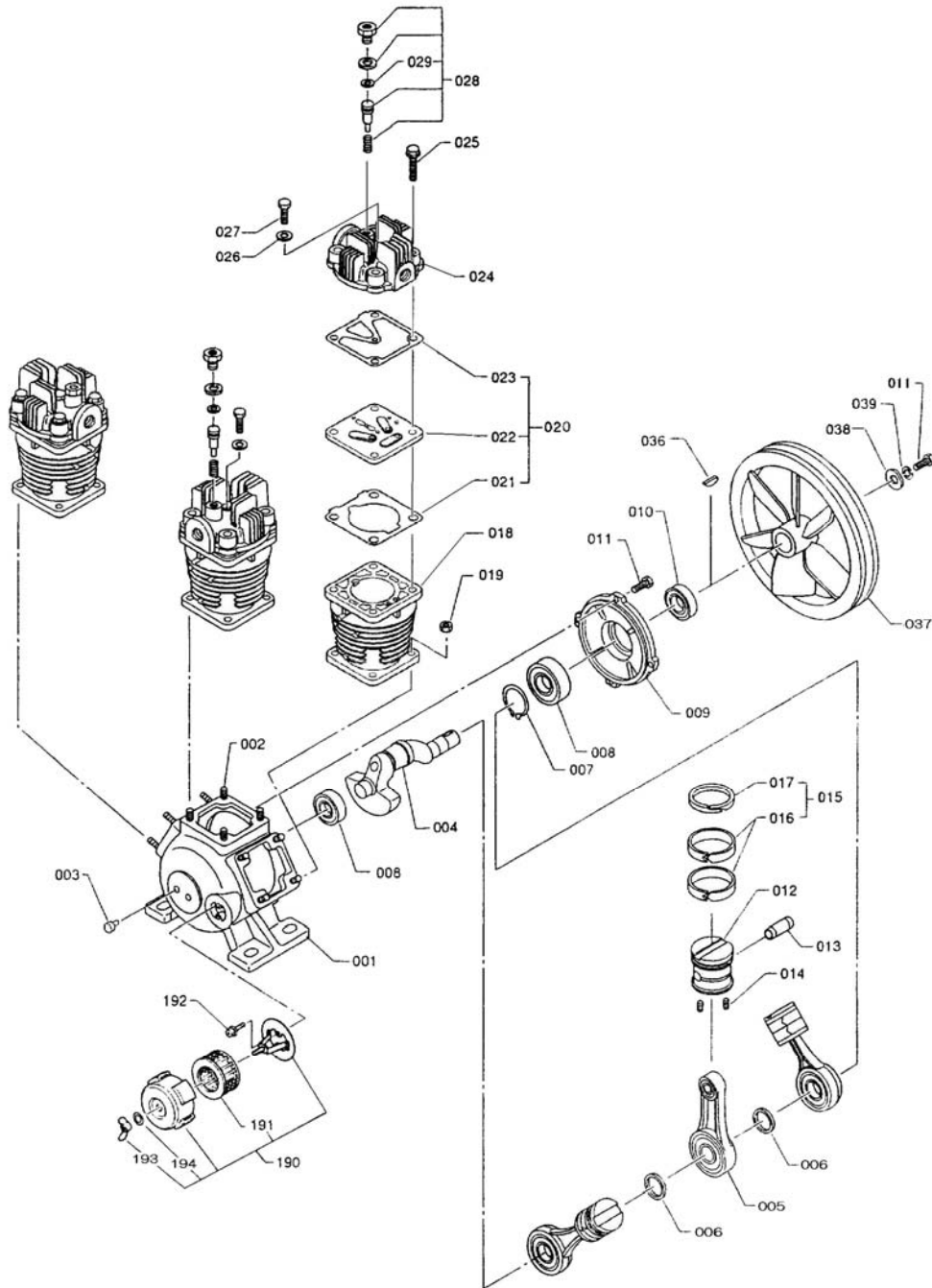

8.0 Replacement Parts

8.5 G-Series

7.5 hp

Ref.	Part No.	Description	Qty/Unit
004	50-20-015	crank shaft	1
005	50-04-004	connecting rod assembly	3
006	50-22-002	thrust ring	2
008	50-05-003	crank case ball bearing	2
009	50-21-010	bearing box	1
010	50-08-002	oil seal	1
012	50-06-012	piston	3
013	50-17-002	piston pin	3
015	50-17-021	bolt	6
016	50-09-003	ring set	3
019	50-13-004	cylinder	3
021	50-01-003	air valve assembly	3
022	50-02-003	air valve packing	3
024	50-07-003	cylinder head packing	3
025	50-14-004	cylinder head	3
026	50-15-002	cylinder head bolt	12
029	50-15-003	packing	3
028	50-11-001	unloader piston set	3
036	50-23-013	compressor pulley key	1
037	50-23-016	compressor pulley	1
038	50-23-011	compressor pulley washer	1
190	50-16-012	crank case filter assembly	1
191	50-06-011	crank case filter element	1

NOTE: Numbered items not shown in the list are not available as individual replacement parts.

8.0 Replacement Parts

8.6 G-Series

10 hp

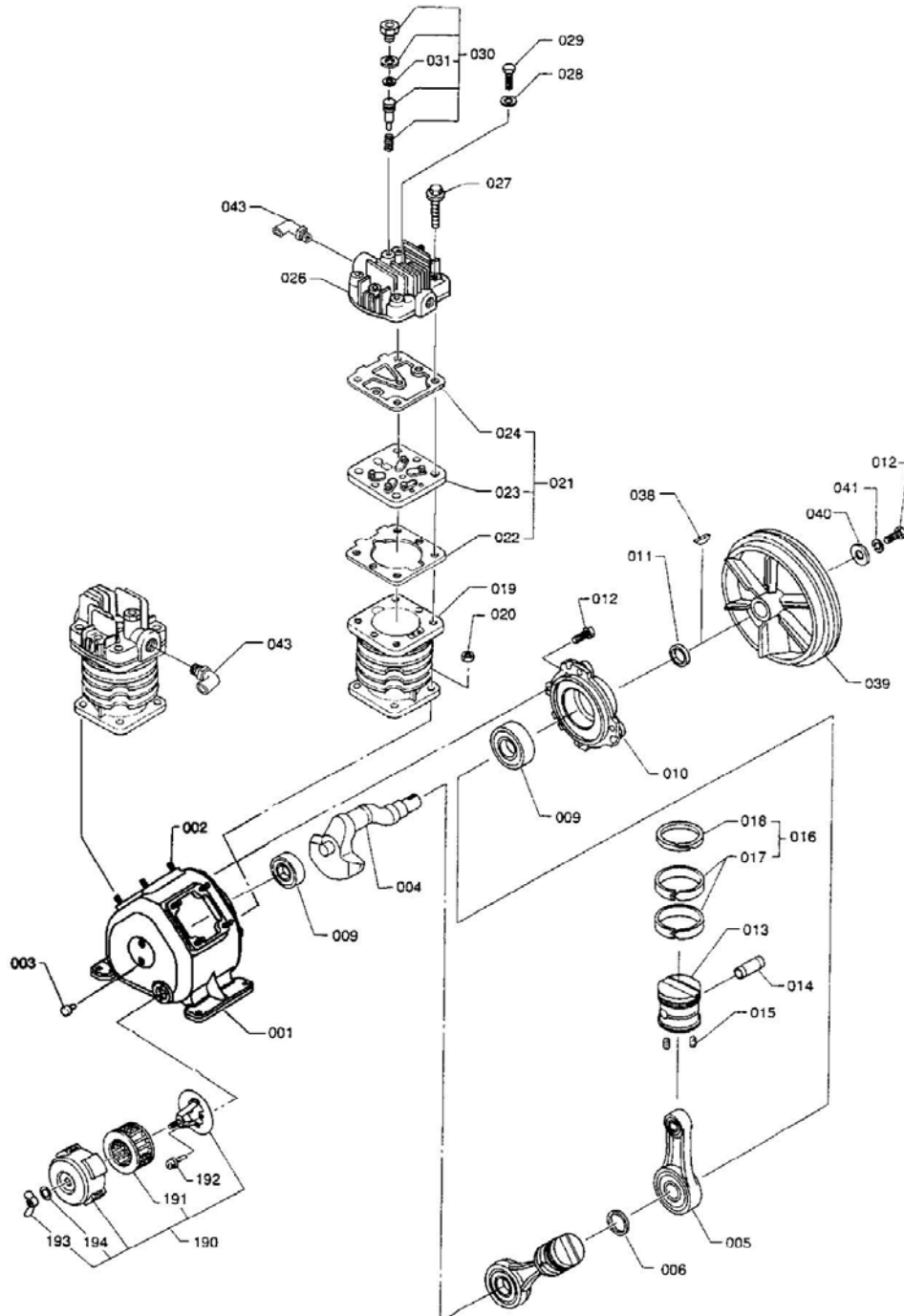

8.0 Replacement Parts

8.6 G-Series

10 hp

Ref.	Part No.	Description	Qty/Unit
004	50-20-016	crank shaft	1
005	50-04-005	connecting rod assembly	2
006	50-22-002	thrust ring	1
009	50-05-003	crank shaft ball bearing	2
010	50-21-005	bearing box	1
011	50-08-002	oil seal	1
013	50-16-004	piston	2
014	50-17-004	piston pin	2
015	50-17-022	bolt	4
016	50-09-006	ring set	2
019	50-13-006	cylinder	2
021	50-01-006	air valve assembly	2
022	50-02-006	air valve packing	2
024	50-07-005	cylinder head packing	2
026	50-14-006	cylinder head U type	2
027	50-15-002	cylinder head bolt	12
028	50-15-003	packing	2
030	50-11-001	unloader piston set	2
038	50-23-013	compressor pulley key	1
039	50-23-017	compressor pulley	1
040	50-23-011	compressor pulley washer	1
190	50-06-010	crank case filter assembly	1
191	50-06-002	crank case filter element	1

NOTE: Numbered items not shown in the list are not available as individual replacement parts.

8.0 Replacement Parts

8.7 G-Series

15 hp

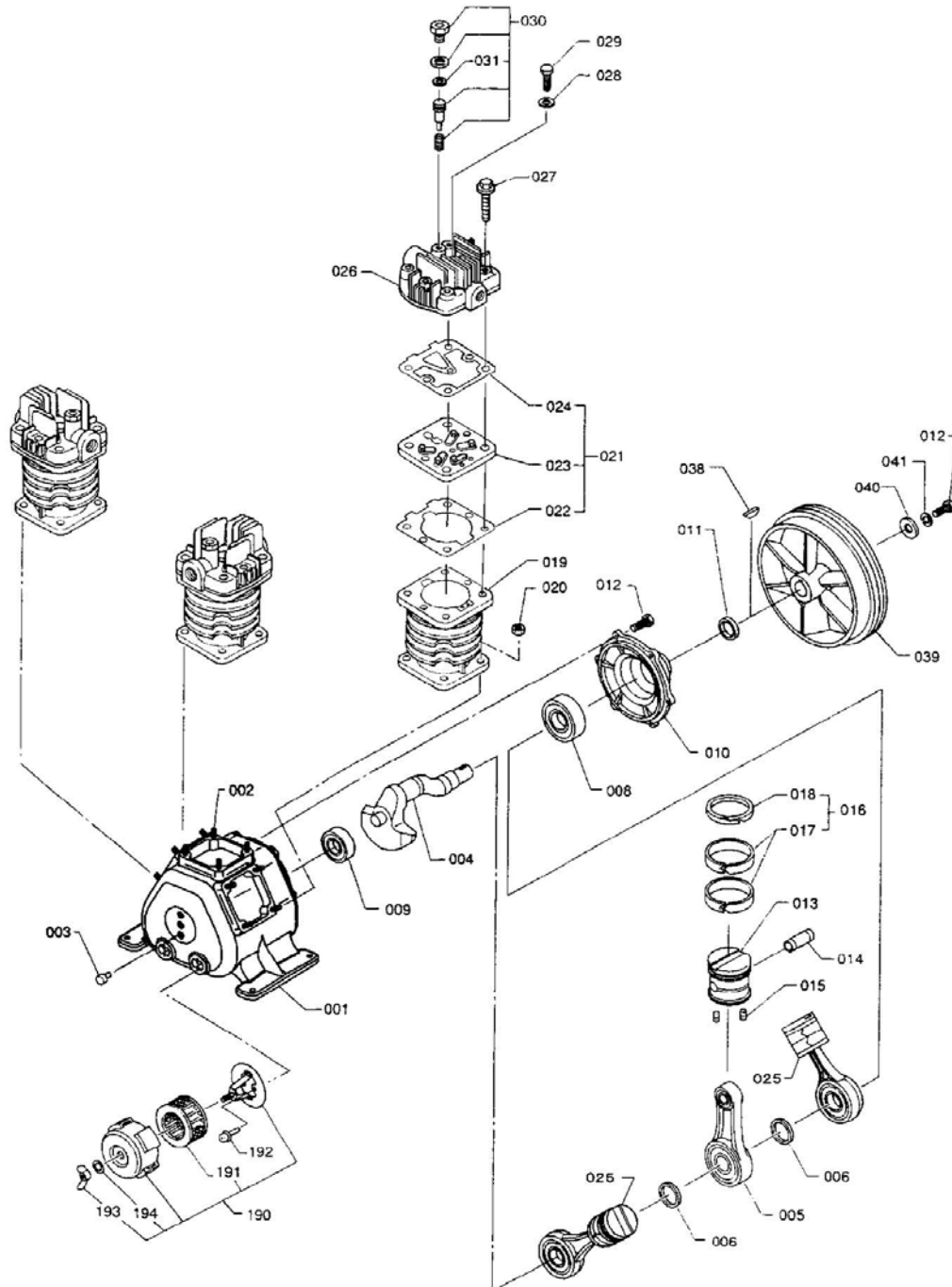

8.0 Replacement Parts

8.7 G-Series

15 hp

Ref.	Part No.	Description	Qty/Unit
004	50-20-017	crank shaft	1
005	50-04-005	connecting rod assembly	3
006	50-22-002	thrust ring	2
008	50-05-007	crank shaft ball bearing	1
009	50-05-008	crank shaft ball bearing	1
010	50-21-011	bearing box	1
011	50-08-003	oil seal	1
013	50-16-005	piston	1
014	50-17-004	piston pin	3
015	50-17-006	bolt	6
016	50-09-006	ring set	3
019	50-13-006	cylinder	3
021	50-01-006	air valve assembly	3
022	50-02-006	air valve packing	3
024	50-07-005	cylinder head packing	3
025	50-16-004	piston	2
026	50-14-006	cylinder head U type	3
027	50-15-002	cylinder head bolt	18
028	50-15-003	packing	3
030	50-11-001	unloader piston set	3
038	50-23-013	compressor pulley key	1
039	50-23-007	compressor pulley	1
040	50-23-011	compressor pulley washer	1
190	50-06-010	crank case filter assembly	2
191	50-06-002	crank case filter element	2

NOTE: Numbered items not shown in the list are not available as individual replacement parts.

8.0 Replacement Parts

8.8 V-Series

20 hp

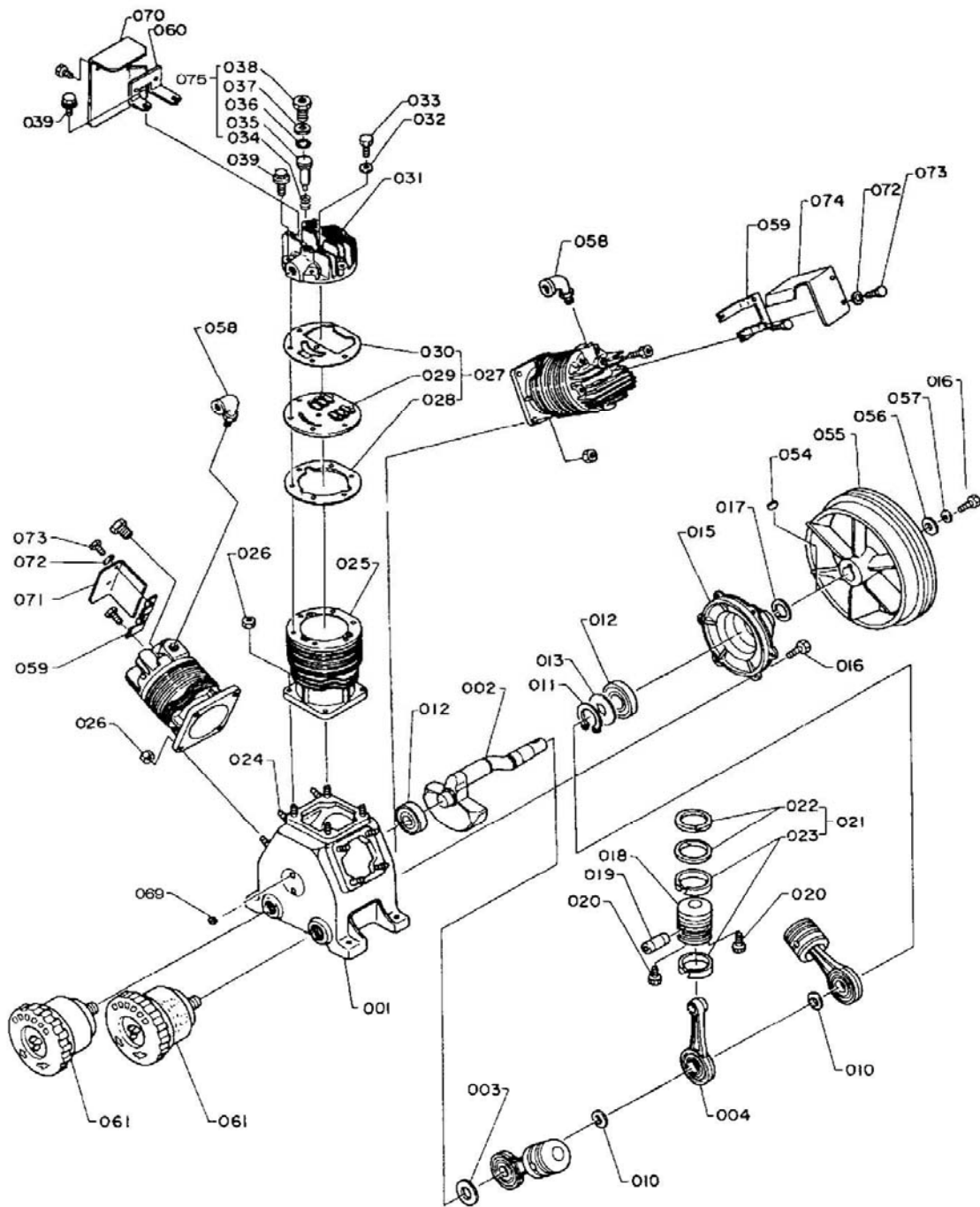

8.0 Replacement Parts

8.8 V-Series

20 hp

Ref.	Part No.	Description	Qty/Unit
002	50-20-008	crank shaft	1
003	50-22-003	crank pin spacer	1
004	50-04-007	connecting rod assembly	3
010	50-22-002	washer	2
013	50-22-005	spacer (bearing)	1
015	50-21-007	bearing box	1
017	50-08-003	oil seal	1
018	50-16-007	piston	3
019	50-17-005	piston pin	3
020	50-17-006	bolt	6
021	50-09-008	ring set	3
025	50-13-007	cylinder	3
027	50-01-007	air valve set	3
028	50-02-007	air valve packing	3
030	50-07-006	cylinder head packing	3
032	50-14-007	head bolt packing	3
034	50-12-003	unloader spring	3
035	50-11-004	unloader piston	3
036	17-01-002	unloader o-ring	3
037	50-18-002	unloader packing	3
038	50-10-002	unloader bushing	3
039	50-15-002	bolt (m12×1.25×55)	18
054	50-23-013	compressor pulley key	1
055	50-23-008	compressor pulley	1
056	50-23-011	compressor pulley washer	1
075	50-11-005	unloader piston set	3
061	50-06-006	crank case filter assembly	2
063	50-06-003	crank case filter element	2

NOTE: Numbered items not shown in the list are not available as individual replacement parts.



Oil-Less Reciprocating Medical Air System

9.0 Warranty

Patton's Medical Systems Warranty

Patton's Medical warrants that all systems to be free of defects in material and workmanship under normal use for a period of twenty-four months from start-up, not to exceed thirty months from date of shipment. This warranty covers all necessary parts used in repair as well as all reasonable labor expense. Normal consumable parts as well as parts requiring calibration as part of routine scheduled maintenance (such as filters, Dewpoint/CO sensors/monitors) are not covered under this warranty.

This warranty does not apply to products that are damaged by external causes, or are improperly warehoused, used, installed, serviced, misapplied or maintained by the customer. The sole liability for **Patton's Medical** under this warranty is limited to repairing, replacing, or crediting, at its election, any such products provided that:

Patton's Medical is notified promptly within the warranty period above of any warranty claim.

The examination of such items by an authorized representative of **Patton's Medical** will disclose to their reasonable satisfaction that claimed products defect has not been caused by misuse, neglect, improper handling, installation, repair, alteration, or accidents.

Patton's Medical requires that systems above 5 Hp simplex be commissioned by an authorized **Patton's Medical** distributor and requires a **legible** start-up report **and distributor invoice** to be filed within 30 days of equipment start-up, **late documentation will not be considered. Failure to submit a start-up report to Patton's Medical will void the warranty.**

Replacement Parts including pumps and motors carry a limited warranty based upon manufacturer specific terms. Labor for these warranties is not included or implied and is at the sole discretion of Patton's Medical.

- Simplex units 5Hp and below as well as retrofit dryer packages do not include factory assisted start-up in their base price unless specifically noted otherwise.

Invoices for work performed, freight, and equipment must be received promptly within 60 -days of performance. Invoices received after this date will not be considered.

Product modification performed by the customer without prior written approval by **Patton's Medical** will invalidate the above warranty.

This warranty is given in lieu of all other warranties, expressed or implied, including implied warranties of fitness for a particular purpose and merchantability. In no event shall Patton's Medical be liable for damages in excess of the value of the defective product or part, nor shall Patton's Medical be liable for any indirect, special or consequential damages, loss of profits of any kind, or for loss of use of the products.

Patton's Medical shall not be liable to the customer for any claims, loss of damage of any kind whatsoever arising from the nonperformance of **Patton's Medical** of any part of this agreement occasioned by acts of God, fire, war, labor difficulties, governmental regulations, or action of government. **Patton's Medical** shall not be liable to the customer for any other cause, whether of a similar or dissimilar nature beyond its reasonable control.



Oil-Less Reciprocating Medical Air System

10.0 Maintenance Record

Model Number _____

Serial Number _____

Installation Date _____

Date of Service					
Hours					
Load					
Ambient Temp.					
Inlet Filter					
Dryer Filters					
Belt Tension					
Misc.					
Serviced By:					

Notes:



Oil-Less Reciprocating Medical Air System

10.0 Maintenance Record

Model Number _____

Serial Number _____

Installation Date _____

Date of Service					
Hours					
Load					
Ambient Temp.					
Inlet Filter					
Dryer Filters					
Belt Tension					
Misc.					
Serviced By:					

Notes:



Oil-Less Reciprocating Medical Air System

10.0 Maintenance Record

Model Number _____

Serial Number _____

Installation Date _____

Date of Service					
Hours					
Load					
Ambient Temp.					
Inlet Filter					
Dryer Filters					
Belt Tension					
Misc.					
Serviced By:					

Notes:



3201 South Boulevard
Charlotte, NC 28209
1-866-960-0087