

LSM Large Screen Mount

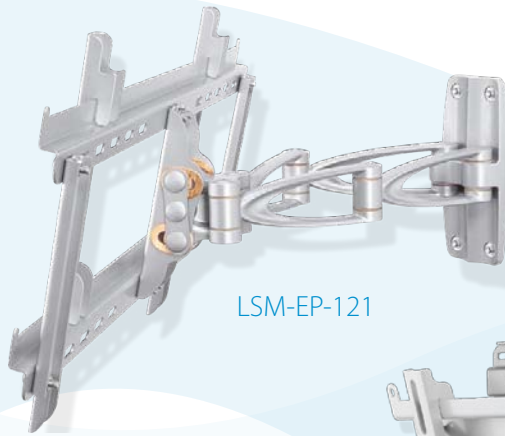

LSM-EP-121

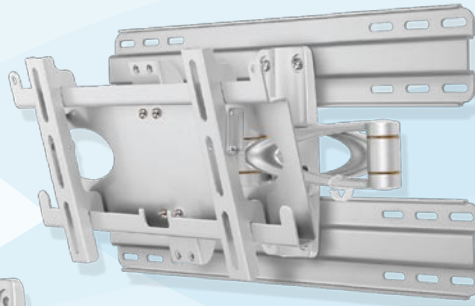

LSM-EP-132

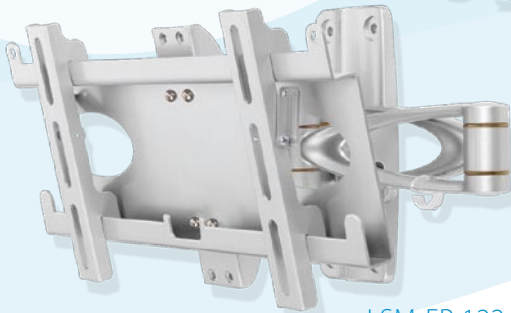

LSM-EP-122

Features:

- Slim Design holds screen close to wall
- Durable Construction makes it ideal for Medical and Clean room environments
- Mounts to steel, wood or concrete
- Tilt function provides optimal viewing comfort
- Adjusts laterally even after installation
- Friction based tilt makes adjustments simple and easy, without the need for knobs and levers
- Can be locked in place to prevent theft
- Mounts are available for any size screen
- Quick and Easy to Install

LCD Monitors

• Toshiba

• Sony

• Samsung

• Gateway

• Advantech

• DELL

• NEC

• LG

Other Manufacturers Options Available

Please specify model when ordering.

LSM Large Screen Mount - Tilt Only



Part Number: LSM-FT-220

- 30° tilt capability
- Stands less than 4" off the wall
- Ideal for flat screens between 32" and 37" up to 176 lbs
- Lateral adjustments are easy even after installation
- Brackets flexible for spacing, HANG-TO-INSTALL



Part Number: LSM-FT-210

- 30° tilt capability
- Stands less than 4" off the wall
- Ideal for flat screens between 37" and 65" up to 176 lbs
- Lateral adjustments are easy even after installation
- Brackets can be installed 4" to 31" apart, HANG-TO-INSTALL



Part Number: LSM-FT-224

- 30° tilt capability
- Stands less than 4" off the wall
- Ideal for flat screens between 32" and 37" up to 176 lbs
- Lateral adjustments are easy even after installation
- 18" Back Plate allows mounting to wall studs, HANG-TO-INSTALL



Part Number: LSM-FT-216

- 30° tilt capability
- Stands less than 4" off the wall
- Ideal for flat screens between 37" and 65" up to 176 lbs
- Lateral adjustments are easy even after installation
- 26" Back Plate allows mounting to wall studs, HANG-TO-INSTALL

LSM Large Screen Mount - Tilt and Pivot

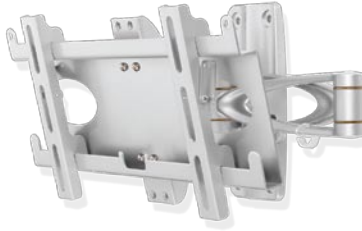

Part Number: LSM-EP-122

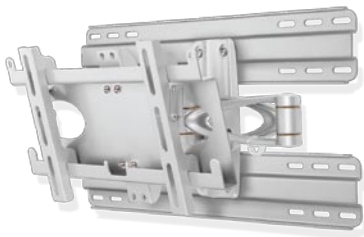

Part Number: LSM-EP-132

- Ideal for flat screens between 32" and 37" up to 80 lbs
- 30° tilt capability
- Simply pull out and swivel for easy viewing
- Conveniently folds against wall when not in use
- Holds screen in any position without the need for knobs or levers
- Mounting Bracket available with LSM-EP-132 to accommodate stud spacing

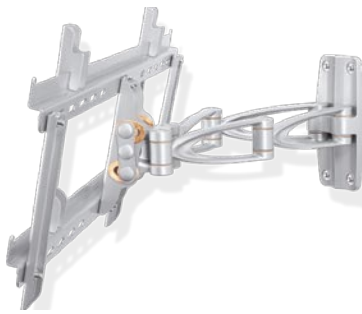

Part Number: LSM-EP-121

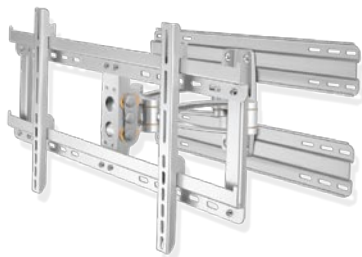

Part Number: LSM-EP-131

- Ideal for flat screens between 37" and 46" up to 80 lbs
- 30° tilt capability
- Simply pull out and swivel for easy viewing
- Conveniently folds against wall when not in use
- Holds screen in any position without the need for knobs or levers
- Mounting Bracket available with LSM-EP-131 to accommodate stud spacing

LSM Large Screen Mount

Flush Mount



- 2.25" (6cm) profile
- 30 lbs (13.60kg) arm rating
- VESA 75/100 plates included
- Portrait and landscape viewing
- 90° tilt capability
- Requires channel, sold separately

Part Number: SSM-LCD-45

Double Pivot Arm 9"x 9"



- 16" (41cm) extension
- 30 lbs (13.60kg) arm rating
- VESA 75/100 plates included
- Portrait and landscape viewing
- 90° tilt capability
- Requires channel, sold separately

Part Number: SSM-LCD-35

Double Pivot Arm 12"x 12"



- 22" (56cm) extension
- 30 lbs (13.60kg) arm rating
- VESA 75/100 plates included
- Portrait and landscape viewing
- 90° tilt capability
- Requires channel, sold separately

Part Number: SSM-LCD-15

Mobile LCD Cart

- Tilt screen up to 40°
- Swivel Base allows for comfortable viewing from any location
- VESA compatible 75mm, 100mm,
- Ideal for flat screens up to 26" max 33 lbs
- Gas spring in shaft enables comfortable height adjustments between 31" and 44" from floor
- Lockable Anti Static castors & infection control surface make this unit ideal for healthcare applications



Part Number: LSM-CART

Please visit www.amico.com for more information on our complete line of monitor accessories.



Distributed By:

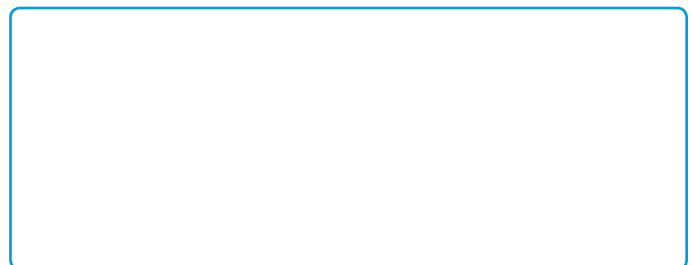

SP-LSM081 PRINTED OCT 08

the right connection